



### General Description

Rotary torque has historically been difficult and expensive to measure. However, by using existing technology in a novel way, inexpensive transducers can be produced for situations where monitoring or control of drive mechanisms is required. Developed in conjunction with a UK government programme, TORQSENSE E300 RWT (Rayleigh Wave Transducers) are the world's first low cost non-contact rotary torque transducers suitable for OEM applications.



TORQSENSE E300 RWT's require a minimal shaft length, have low inertia, no physical contact between shaft and housing, wide bandwidth, high resolution, high accuracy and excellent noise immunity.

Each TORQSENSE E300 RWT contains an embedded non-volatile memory chip storing data on parameters, calibration etc., which are passed to the stand alone E302 interface/readout and then if required to a host PC operating TORQVIEW 2, a virtual instrumentation display system. This provides the user with a very cost-effective solution to measuring, recording and displaying data from a wide variety of applications. Please refer to relevant data sheets for information on E302 interfaces and TORQVIEW 2. All TORQSENSE RWTs operate statically as well as dynamically.

### Technology

The patented method uses surface acoustic wave devices as essentially 'frequency dependent' strain gauges to measure the change in resonant frequency caused by an applied shaft strain. The signal is coupled via a non contact RF rotating couple from the shaft to a fixed pick-up. Saw devices are not affected by magnetic fields.

### Standard Specifications

Model	Full Scale Deflection		Max speed (RPM)
	Min FSD	Max FSD	
E300 RWT1-1B	0 - 50 mNm 0 - 0.5 lbf.in	0 - 100 mNm 0 - 1 lbf.in	30,000
E300 RWT1-1A	0 - 101 mNm 0 - 1 lbf.in	0 - 500 mNm 0 - 5 lbf.in	30,000
E300 RWT1-1	0 - 501 mNm 0 - 5 lbf.in	0 - 1 Nm 0 - 10 lbf.in	30,000
E300 RWT1-2	0 - 1 Nm 0 - 10 lbf.in	0 - 20 Nm 0 - 200 lbf.in	20,000
E300 RWT1-3	0 - 20 Nm 0 - 200 lbf.in	0 - 100 Nm 0 - 1000 lbf.in	15,000
E300 RWT1-4	0 - 100 Nm 0 - 1000 lbf.in	0 - 200 Nm 0 - 2000 lbf.in	14,000
E300 RWT1-5	0 - 200 Nm 0 - 2000 lbf.in	0 - 500 Nm 0 - 5000 lbf.in	12,000
E300 RWT1-6	0 - 500 Nm 0 - 5000 lbf.in	0 - 2000 Nm 0 - 20,000 lbf.in	9,000
E300 RWT1-7	0 - 2000Nm 0 - 20,000 lbf.in	0 - 10000Nm 0 - 100,000 lbf.in	6,000

*Calibration in any equivalent units below is possible. The FSD can be set to any value within the range of a specific model and the torque measurement is therefore from zero to that FSD. For example, a 30 Nm FSD transducer would require an E300 RWT1-3 and it would measure from 0 to 30 Nm, bi-directionally.*

## Standard

Cable length	2 metres - see options 3&4	Interface readout	E302
Outputs	From E302 module ( $\pm 5V$ )		
Power supply	From E-302 interface	Safe mechanical overload	300% of rating
Accuracy	$\pm 0.25\%$ FSD; $\pm 0.1\%$ to order	Memory	Embedded non-volatile memory chip
Bandwidth	Better than 2KHz	Hysteresis	Better than 0.1%
Output frequency	$\pm 200KHz$ for $\pm$ full scale at change	Bearings	Deep grooved shielded bearings with oil lubrication-see options 5&6
Temperature range	-10°C to + 50°C	Temperature coefficient	Less than 0.05% per °C.

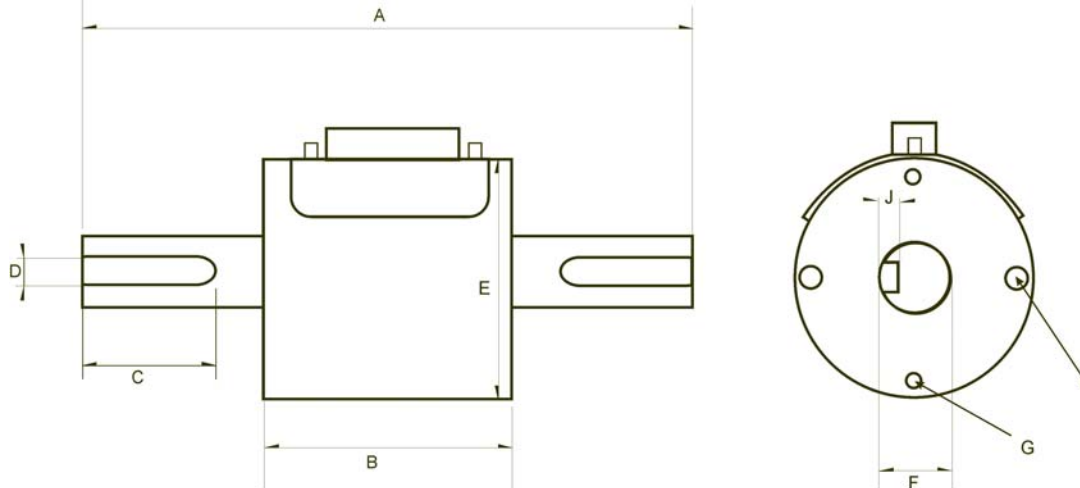

## Mechanical Parameters

Model	Dimensions (mm)										Rotational Inertia (NmSec <sup>2</sup> )	Critical Speed (Rad/Sec)	Natural Freq (Hz)	Torsional Stiffness (Nm/Rad)
	A	B	C	D	E	F	G	H PCD	J					
RWT1-1, 1A, 1B	125	72	N/A	N/A	62	6	M3	56	N/A	$1.48 \times 10^{-7}$	$3.98 \times 10$	$3.76 \times 10^3$	$9.28 \times 10$	
RWT1-2	125	72	18	4	62	12	M3	56	2	$1.82 \times 10^{-5}$	$1.09 \times 10^2$	$4.68 \times 10^3$	$2.04 \times 10^3$	
RWT1-3	172	80	30	6	68	20	M3	62	3.5	$2.17 \times 10^{-5}$	$1.28 \times 10^2$	$2.90 \times 10^3$	$9.92 \times 10^3$	
RWT1-4	194	82	37.5	8	80	25	M3	74	4	$5.41 \times 10^{-5}$	$1.45 \times 10^2$	$2.78 \times 10^3$	$2.54 \times 10^4$	
RWT1-5	216	82	45	10	80	30	M3	74	5	$1.15 \times 10^{-4}$	$1.57 \times 10^2$	$2.64 \times 10^3$	$5.42 \times 10^4$	
RWT1-6	260	90	70	16	98	50	M3	92	6	$1.15 \times 10^{-3}$	$2.16 \times 10^2$	$2.05 \times 10^3$	$3.78 \times 10^5$	
RWT1-7	284	96	85	22	150	75	M5	140	9	$7.47 \times 10^{-3}$	$2.71 \times 10^2$	$1.63 \times 10^3$	$1.50 \times 10^6$	

## Options

Option	Description	Information/remarks
1	Optical RPM Pickoff	External dimensions are not affected
2	Transducer Sealing to IP65	Some external dimensions change. Maximum running speeds will be considerably reduced, and drag torque will increase - Consult factory
3	Extension Cable	Between 2 metres and 10 metres a standard or heavy-duty extension cable may be used. Please specify required length
4	Cable Driver	Between 10 metres and 120 metres, a cable driver is fitted close to the transducer together with an extension lead. Please specify required length
5	High Speed Bearings	At very high speeds, for better balance, we recommend plain or splined shafts - Consult factory. See chart below for max speeds
6	Sealed Bearings	See chart below for max speeds

Max speed (Note: quoted in RPM with no radial or side loads)

Option	RWT1-1, 1A, 1B	RWT1-2	RWT1-3	RWT1-4	RWT1-5	RWT1-6	RWT1-7
5	Consult factory	30,000	25,000	23,000	20,000	14,000	9,000
6	15,000	12,000	9,000	8,000	7,000	4,500	3,000
Standard	30,000	20,000	15,000	14,000	12,000	9,000	6,000

Patents pending. US Patents: US5585571, US6478584.

*Sensor Technology Ltd reserves the right to change specification and dimensions without notice.  
See cover page or contact company for warranty and EMC compliance*