



RWT310/320 SERIES TRANSDUCER

PRODUCT DATA SHEET

0.5Nm to 10,000Nm





TORQSENSE

Rotary torque has historically been difficult and expensive to measure. However with TORQSENSE technology that was developed in conjunction with a UK government programme, RWT310 & 320 series transducers can now offer *cost effective, non-contact* rotary torque transducers suitable for monitoring, testing or assist controlling drive mechanisms. TORQSENSE RWT310 & 320 series transducers are particularly *appropriate for OEM* applications.



Benefits

- Minimal shaft length
- Low inertia
- No physical contact between shaft and housing
- Wide bandwidth
- 250% mechanical overload
- High accuracy and resolution
- Excellent noise immunity
- Integral electronics
- Operates statically as well as dynamically - Clockwise/anti-clockwise
- Ability to specify any full scale torque

Additionally, TORQSENSE RWT320 series transducers offer

- Digital and analog user selectable features such as voltage and current outputs
- USB
- RS232
- Self-diagnostics

Standard range: 500mNm through to 10,000Nm. Above 10,000Nm on request.
High speeds on request.

Technology

TORQSENSE patented technology uses 'frequency dependent' surface acoustic wave devices to measure the change in resonant frequency caused by an applied shaft strain. The signal is coupled via a non-contact RF rotating couple from the shaft to a fixed pick-up. SAW devices are not affected by magnetic fields. Integral electronics allows the resonant frequencies to be measured and offer user selectable features, digital outputs and diagnostics.

TORQVIEW 2

An easy to use software tool, TORQVIEW 2, a Virtual Instrumentation Display PC Interface Software, can also be used to assist data recording.

Features: 3 display types, and text files compatible with Matlab and Excel.

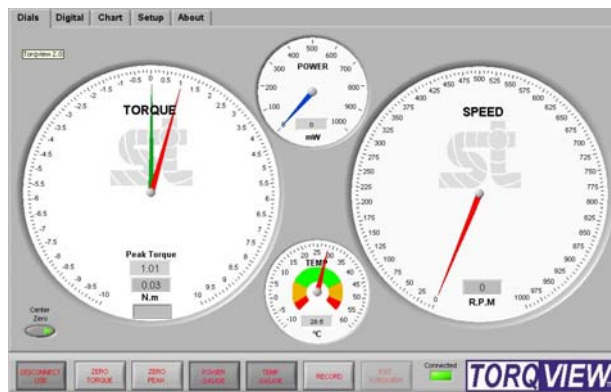

Lifetime Warranty

Sensor Technology Ltd's standard range of torque measuring products are warranted against manufacturing defects and component failure for two years from date of purchase, subject to fair wear and tear and return for the first year's free of charge annual re-calibration. This warranty is extended indefinitely if the equipment is returned to Sensor Technology, or its distributor for annual re-calibration, when software and hardware updates, if required, will be carried out free of charge. Standard range means those products described in the company's product data sheets.

US Patents: US5585571, US6478584.

RWT310/320 Series Torque Transducers - Data Specification (PRELIMINARY)

Parameter	Condition	Data						Units
RWT310/320 Torque measurement system								
• Measurement method	Strain-sensitive Surface Acoustic Wave devices							
• Torque range (see Notes 1 & 2 below)		0.5 to 1 [5 to 10]	1.1 to 20 [11 to 200]	21 to 100 [201 to 1000]	101 to 500 [1001 to 5000]	501 to 2000 [5001 to 20000]	2001 to 10000 [20001 to 100000]	Nm [lbf·in]
• Shaft size (diameter)		6	12	20	30	50	75	mm
• Linearity	@ 20°C	<0.5						%FS
• Hysteresis	@ 20°C	<0.1						%FS
• Accuracy	@ 20°C	±0.25						%FS
• Resolution	@ 20°C	±0.1						%FS
• Long term stability	48h	0.8						%FS
Rotation speed/angle of rotation measurement system								
• Measurement method	IR optical transceiver through slotted disc							
• Output signal	Digital, TTL level (5V, square wave signal)							
• Update rate (frequency mode above 80 rpm)	Fixed output	1						second
• Update time (period mode below 80 rpm)	Variable output	1000/(rpm x 60)						ms
• Rotation speed (max)	@ 20°C	30,000	20,000	15,000	12,000	9,000	6,000	Rpm
Temperature								
• Measurement method	IR temperature sensor monitoring actual shaft temperature							
• Temperature accuracy		±1						°C
• Reference temperature, T _{RT}		20						°C
• Operating range, ΔT _O		-10 to +50						°C
• Storage range, ΔT _S		-20 to +70						°C
• Temperature drift		0.05						%FS/°C
Digital output (RWT320 Series Transducers ONLY)								
• Output type	RS-232, USB (optional)							
• Sampling rate		1.62						ksps
• Digital averaging (see Note 3)		Accuracy				Bandwidth		%FS Hz
o N=1		±1				1620		
o N=2		±0.7				810		
o N=4		±0.5				405		
o N=8		±0.4				202		
o N=16 (default)		±0.25				101		
o N=32		±0.25				50		
o N=64		±0.25				25		
o N=128		±0.25				12		
Analogue output								
• Output voltage		±1 to ±10 (user selectable on RWT320 Series)						Vdc
• Output current		0-20 or 4-20 (user selectable on RWT320 Series)						mA
• Load impedance		25						KΩ
Power supply								
• Nominal voltage, V _S		11 to 32 (max)						V
• Current consumption, I _S		290 (max)						mA
• Power consumption, W _S		3.5						W
• Allowed residual ripple of excitation voltage, V _{ripple}		500 (above nominal supply voltage)						mVp-p
Electromagnetic compatibility								
EMC compatibility		EN 55011 & EN 61326-1						

Note 1. Any torque/FSD is possible between ranges – please specify rated torque.

Note 2. Max rated torque should not be exceeded.

Note 3. Digital averaging can be configured to optimise accuracy/bandwidth for specific customer applications. For details see User Manual.

RWT310/320 Series Torque Transducers (PRELIMINARY)

Dimensions (0.5Nm to 100Nm)

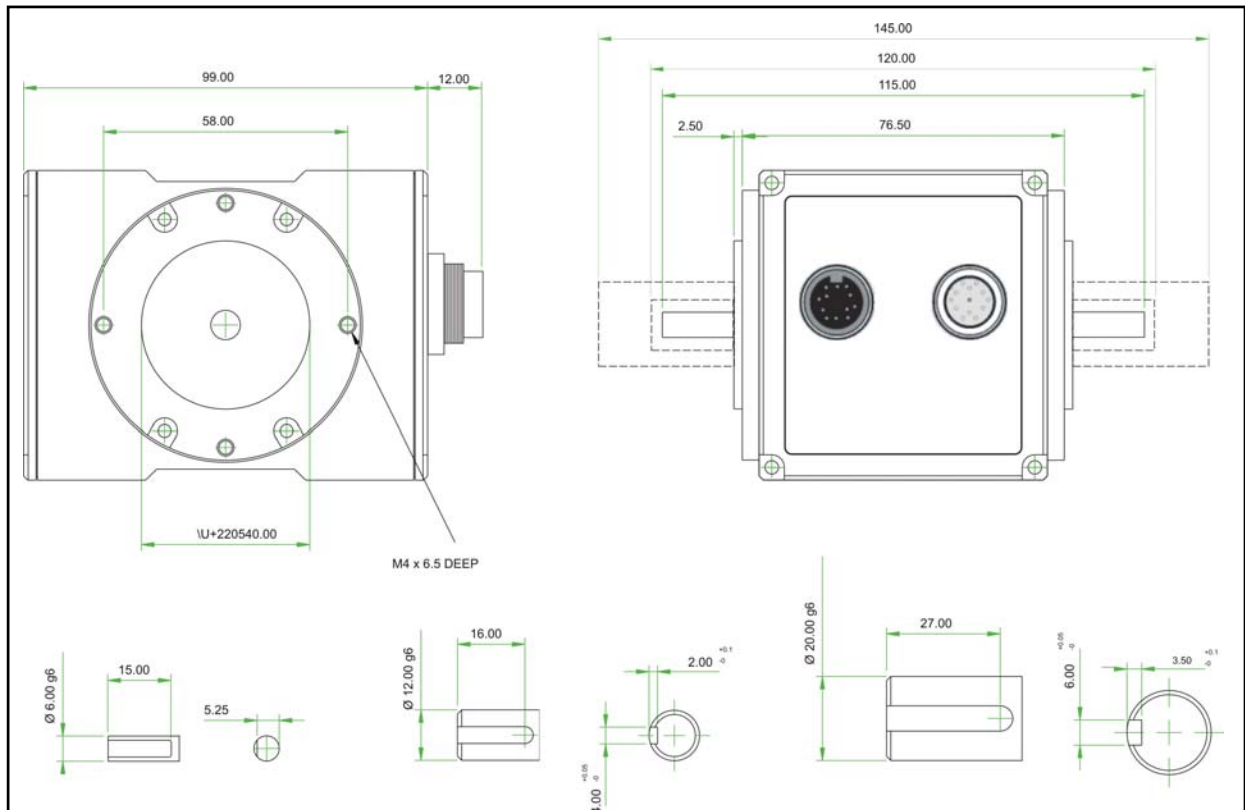

Parameter	Condition	Data											Units
Mechanical Properties													
• Torque (Max)		0.6	1	2.5	6	12	17.5	20	30	55	85	100	Nm
• Shaft Code		CE	CF	DA	DB	DC	DD	DE	EB	EC	ED	EE	
• Shaft Size (Diameter)	@ 20°C	6			12				20				mm
• Torsional stiffness, c_T	@ 20°C	1.3	1.7	3.2	4.3	5.8	1.7	1.9	6.3	9.3	11.4	12.6	KNm/rad
• Mass moment of inertia, L_V	@ 20°C	3.03	3.06	5.89	5.65	6.05	6.09	6.26	1.68	1.77	1.92	2.11	$\times 10^{-6}$ kg m ²
• Max measurable load limit	@ 20°C	120 (of rated torque)											%
• Static load breaking	@ 20°C	250 (of rated torque)											%
• Shaft weight, approx	@ 20°C	0.03	0.03	0.14	0.14	0.14	0.15	0.15	0.36	0.37	0.40	0.41	kg
• Transducer with shaft weight, approx	@ 20°C	0.71	0.71	0.82	0.82	0.82	0.83	0.83	1.04	1.05	1.08	1.09	kg

Sensor Technology Ltd reserves the right to change specification and dimensions without notice.

RWT310/320 Series Torque Transducers (PRELIMINARY)

Dimensions (101Nm to 500Nm)

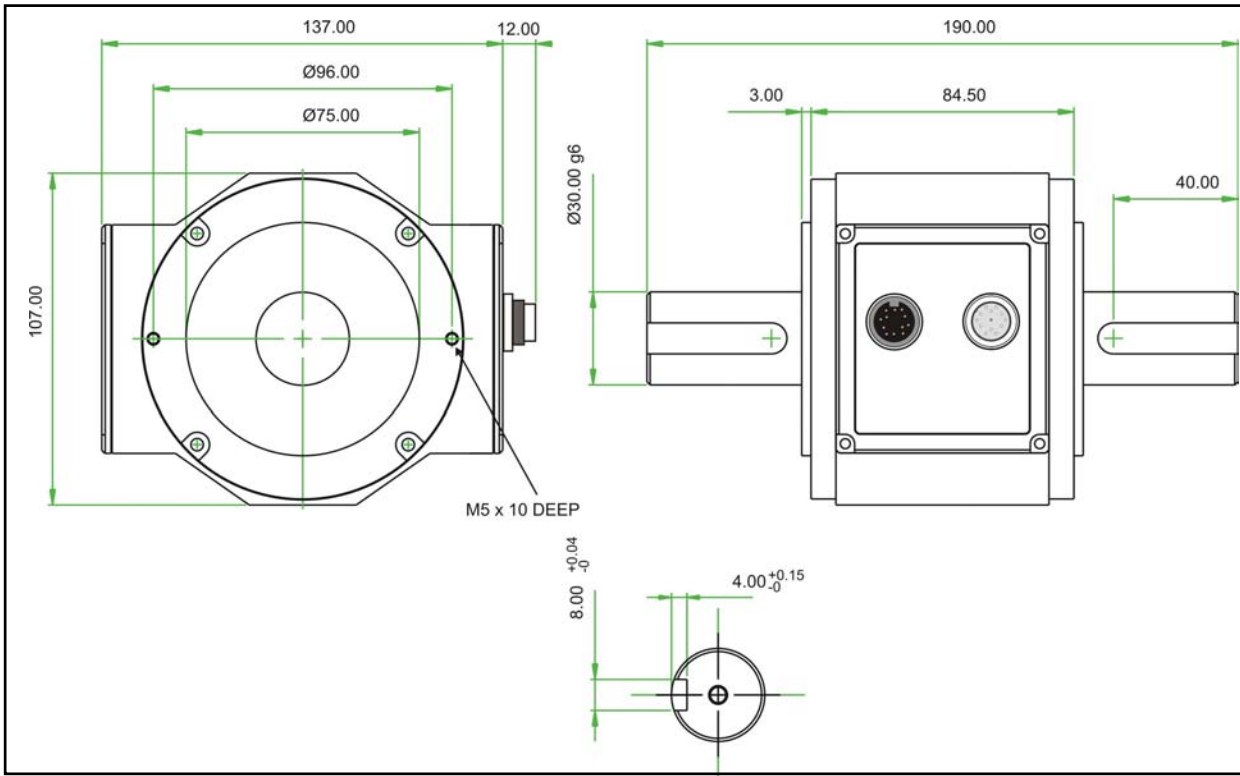

Parameter	Condition	Data					Units
Mechanical Properties							
• Torque (Max)		175	225	265	350	500	Nm
• Shaft Code		FA	FB	FC	FD	FE	
• Shaft Size (Diameter)	@ 20°C	30					mm
• Torsional stiffness, C_T	@ 20°C	TBC					KNm/rad
• Mass moment of inertia, L_V	@ 20°C	TBC					$\times 10^{-6}$ kg m ²
• Max measurable load limit	@ 20°C	120 (of rated torque)					%
• Static load breaking	@ 20°C	250 (of rated torque)					%
• Shaft weight, approx	@ 20°C	TBC					kg
• Transducer with shaft weight, approx	@ 20°C	TBC					kg

Sensor Technology Ltd reserves the right to change specification and dimensions without notice.

RWT310/320 Series Torque Transducers (PRELIMINARY)

Dimensions (501Nm to 10000Nm)

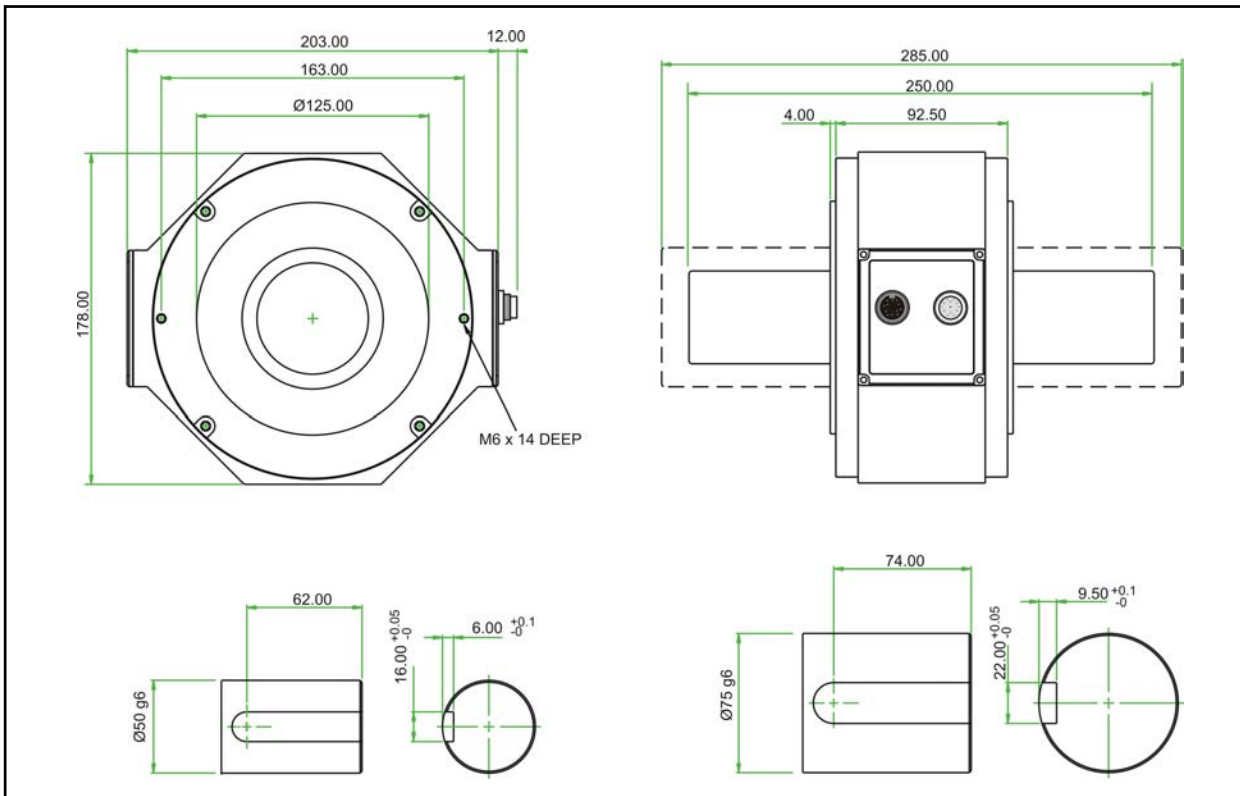

Parameter	Condition	Data				Units
Mechanical Properties						
• Torque (Max)		1100	2000	6000	10000	Nm
• Shaft Code		GB	GD	HC	HF	
• Shaft Size (Diameter)	@ 20°C	50		75		mm
• Torsional stiffness, c_T	@ 20°C	TBC				KNm/rad
• Mass moment of inertia, L_v	@ 20°C	TBC				$\times 10^{-6}$ kgm ²
• Max measurable load limit	@ 20°C	120 (of rated torque)				%
• Static load breaking	@ 20°C	250 (of rated torque)				%
• Shaft weight, approx	@ 20°C	TBC				kg
• Transducer with shaft weight, approx	@ 20°C	TBC				kg

Sensor Technology Ltd reserves the right to change specification and dimensions without notice.

RWT310/320 Series Torque Transducers - Standard Range (PRELIMINARY)

● – Standard feature ○ – Optional feature

	RWT310/320 Series		Option Code	Remarks
	RWT310	RWT320		
Torque, Speed, Power Outputs				
Torque only	310	320		
Torque & Speed (Low Resolution)	311			<i>Specify RPM/FSD (60 pulses / rev)</i>
Torque & Speed (High Resolution)	312			<i>Not yet available (360 pulses / rev)</i>
Torque & Power	313			<i>Specify Power/FSD</i>
Torque & Angle	314			<i>Not yet available</i>
Torque & Speed (Low Resolution) or Power		321		<i>User self selectable (60 pulses / rev)</i>
Torque & Speed (High Resolution) or Power or Angle		322		<i>Not yet available (360 pulses / rev)</i>
Standard features				
Keyed Shaft Ends	●	●	K	
Voltage Output ±5v FSD	●		B	
Voltage Output ±1v to ±10v FSD		●		<i>User self selectable</i>
RS232 Output		●		
Torque Averaging		●		
Torque Peak		●		
Self Diagnostics		●		
Internal Temperature Reading		●		
Deep grooved shielded bearings with oil lubrication	●	●		
Optional features				
Plain Shaft Ends	○	○	P	
Voltage Output ±1v FSD	○		A	
Voltage Output ±10v FSD	○		C	
Current Output 0-20mA	○		D	<i>Not yet available</i>
Current Output 4-20mA	○		E	
Current Output (0-20mA or 4-20mA)		○	F	<i>User self selectable</i>
USB Digital Output		○	G	
High Speed Bearings <i>(See Note 3 below)</i>	○	○	J	<i>Consult factory for max speed allowances</i>
Sealed Bearings	○	○	S	
IP65 <i>(See Note 4 below)</i>	○	○	L	
<i>When you order a Torque Transducer please note that any torque/FSD is possible between ranges – please specify rated torque and options. Please use the following format:</i>				

For example: RWT	311 - 15Nm -	K-BEL	A 'basic' transducer with torque and speed output rated and calibrated to 15Nm FSD with keyed ends, ±5v, 4-20mA outputs and IP65 protection.
Your transducer requirement: RWT			
Speed (if applicable)		RPM	
Connector & Lead Code (if applicable) See over			

Note 1. Any torque/FSD is possible between ranges – please specify rated torque.

Note 2. Max rated torque specified should not be exceeded.

Note 3. At very high speeds, for better balance the factory recommend plain or splined shafts.

Note 4. Max running speeds will be considerably reduced and drag torque will increase.

RWT310/320 Series Torque Transducers - Connector and Lead Options (PRELIMINARY)

○ – Optional accessory

	RWT310/320 Series		Option Code	Remarks
	RWT310	RWT320		
Connectors & Leads				
Analog Connector- 12 Pin Lumberg (female)	○	○	ACC 1	<i>For user to self wire</i>
Digital Connector- 12 Pin Lumberg (male)		○	ACC 2	<i>For user to self wire</i>
2.5m Analog Lead - 12 pin Lumberg (female) to 15 way 'D' type connector (female) and Dongle	○	○	ACC 3	<i>For connecting RWT to user's system via 15 pin 'D' connector</i>
2.5m Digital Lead - 12 pin Lumberg (male) to 15 way 'D' type connector (male) and 15 way 'D' type Connector blank (female)		○	ACC 4	<i>For connecting RWT to user's system via 15 pin 'D' connector</i>
Digital Lead Adapter containing Power Connector and RS232 Connector		○	ACC 5	<i>For connecting ACC 4 to PC via RS232</i>
Digital Lead Adapter containing Power Connector, RS232 Connector and USB Connector		○	ACC 6	<i>For connecting ACC 4 to PC via USB (OPTN G) or RS232</i>
AC Mains Adapter Power Supply	○	○	ACC 7	<i>To provide power for RWT310/320</i>
Breakout Box	○	○	ACC 8	<i>Not yet available</i>

Please specify your connector and lead option code, if applicable, with your order.