

Examples.

The examples below shows the HPL410 used as a max. or a min. load protection unit. When a limit is crossed an alarm is generated and the relay is toggled. The drawing does not show how the alarm relay is used in the actual protection scheme (application specific). The alarm must be reset, either using the reset key located on the front panel or from the external reset input, S1. In these examples the HPL410 is mounted directly at the motor-switch, after the fuses. This enables the use of Phase asymmetry supervision (motor-fuse blown). If the input

S1 and Grd are shorted (Auto-Reset), then the alarm activates the hysteresis function, implementing a simple two-point regulation scheme. This is for instance used in a grinding mill where the HPL410 measures the power consumption of the mill, but the relay output controls the feeder mechanism (belt, screw etc). The input S2 is used to disable the max. & min. alarms and its primary function is to avoid the generation of a min. power alarm when the motor is stopped intentionally (normal shut down). If the motor current exceeds 8 Amp. then an external current converter must be mounted as shown in the second example below.

Note!!! An external current converter must always be mounted in the L3-phase for correct measurements. The converter polarity is not important.

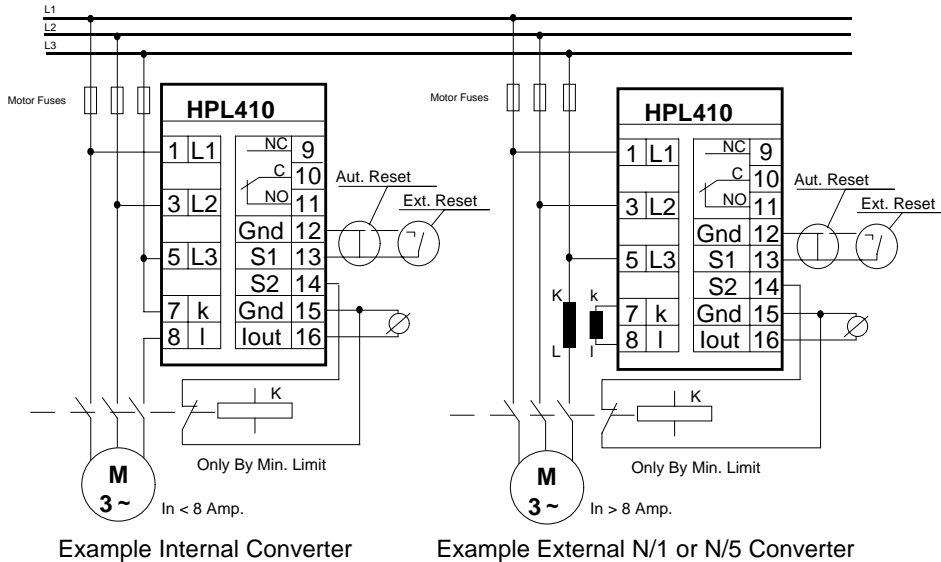

If you need further information about the HPL-family of **Intelligent Power-Control Units** and its ability to solve your problems, please do not hesitate to contact us.

WENtechnology
 Raleigh, NC, USA
 (919) 954-1004 www.wentec.com

Unipower

Version 3.3
 HPL410

Technical Information

English Edition

Technical Specification

Electrical

Voltage Ranges

See technical info on the unit.
 Also Available:
 3 x 120 VAC -> 3 x 575 VAC

Current Range

Internal: max. 8 A.
 External: N/1 or N/5 converter.

Cosφ Range: 0-1.

Frequency Range: 45-65 Hz.

Consumption

Supply voltage = measurement voltage, 3 VA.

Relay Output: 250 VAC/5 Amp.

Analog Output

4-20 mA, 0-400 Ohm, electrically isolated from the measurement system.

Mechanical

Housing

Makrolon 8020 (30% GV), UL94V-1 (house).
 Makrolon 2800, UL94V-2 (connector + front).

Mounting

Snap-on construction for 35mm DIN rail mounting or panel mounting.

Protection Class

IP40 (house).
 IP20 (connector).

Temperature Range: -15 - +50 °C.

Weight: Approximately 500g.

Dimensions

D 75 x W 56 x H 110 mm.

Terminal tight. torque: 7lbs/in, 0.79Nm

Use 60/75 copper (CU) wire only

CE mark to:

EN50081-1, EN50082-2, EN61010-1

UL certified:

UL 508 - Industrial Control Equipment

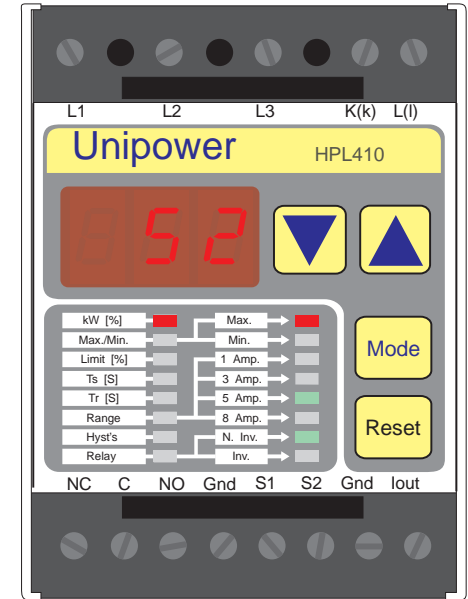

THE CONCEPT

The Unipower HPL410 is a member of a family of **"Intelligent Power-Control Units"**, which is based upon the latest advance in Microcontroller Technology. The unit measures true power-consumption and shows the consumption as a percentage of the selected power-range. The power-consumption (kW) is calculated from the following formula:

$$P = \sqrt{3} \times U \times I \times \text{Cos}\phi$$

The primary function of the unit lies in the supervision and control of machinery driven by 3-phase AC-motors. The HPL410 integrates a max. or min. kW limit detector plus the support functions necessary to establish the efficient and compact supervision or regulation of various types of machinery such as pumps, ventilators and conveyor belts. As well as the support functions Ts, Tr, hysteresis etc. the HPL410 has a built in current converter that works up to 8 Amp.

Programming & Display.

Mode	Function	Variable	▼	+	▲	Display	Default
[kW] %	Normal Mode		Min. Peak	Po	Max. Peak	kW [%]	
Max./Min.	Max./Min. Mode	Max. or Min.	Min <--> Max	Min <--> Max	"==="		Max.
Limit [%]	Limit	5-100%	Decrease	Increase	Limit [%]		80%
Ts [S]	Start Delay	0.1-25.0 Sec.	Decrease	Increase	Ts [Sek]		2.0 Sec.
Tr [S]	Alarm Reaction Delay	0.0-25.0 Sec.	Decrease	Increase	Tr [Sek]		0.1 Sec.
Range	Current Range	1, 3, 5, 8 Amp.	8 --> 1	1 --> 8	"Cur"		5 Amp.
Hyst's	Hysteresis	2-50%	Decrease	Increase	Hyst's [%]		10%
Relay	Relay Polarity	N. Inv./ Invert.	N.Inv<-->Inv	N.Inv<-->Inv	"Pol"		N. Inverted

The HPL410 is programmed by the use of only three keys located on the front panel. The mode key is used to switch the display from showing kW [%] to display one of seven programmable variables. All the variables and their programming ranges are listed in the function table above. The red mode LED is used to show which variable may be altered. When a variable has been selected by the mode key, then its value is shown on the display and may be altered by the two arrow-keys. Note that the keys are repeated if held down continuously. Variables are stored in EEPROM. When no key has been activated for about 5 seconds the display returns to the kW [%] position (Normal Operation). When the Dip. Sw. 1 is 'On' the unit is protected against programming; but it is still possible to display current settings.

LED Usage	
Max. Alarm	Max. LED flashing
Min. Alarm	Min. LED flashing
Start Delay	Ts LED lit
Alarm Delay	Tr LED lit
Relay Closed	Relay LED lit

Phase Error	Display
Phaseorder L1 L3 L2	PH 1 (flashing)
Voltaged eviation > 8 %	PH 2 (flashing)
Phase deviation > 5 degree	PH 3 (flashing)

DIP Switch Usage		
SW 1	Unit protected	ON
SW 2	Phase order sup.	ON
SW 3	Phase asymmetri sup.	ON
SW 4	Measure and subtract P ₀	ON

The Phase order supervision generates an alarm if the three phases L1, L2 and L3 are out of order. The Phase asymmetry supervision is a combination of voltage-deviation and phase-deviation examination. A phase error toggles the relay in exactly the same way as the crossing of a limit and the display shows which type of error has occurred. A phase error is automatically reset when it has been corrected. During a phase error the 4-20mA signal lout is set to 0 mA (remote alarm signalling).

Dip. Switch Access.

1. Disconnect the Mains Power.
2. Remove the plastic cover. (Use a small screwdriver).
3. Change the switch settings and assemble the unit again.

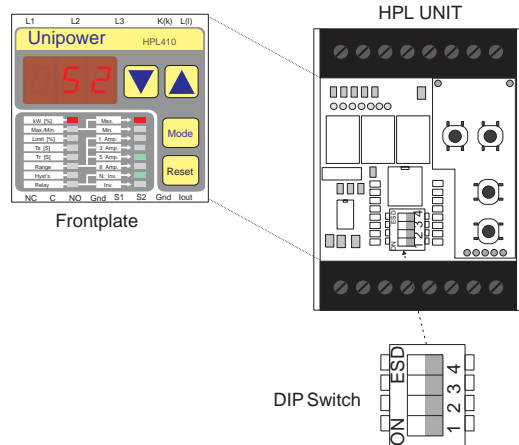

Function.

The drawing below shows a typical AC-motor power consumption curve immediately after power has been applied to the motor. The programmable start timer (Ts) is used to filter out from the protection/regulation cycle the large power consumption generated by the motor when starting. The Ts delay function is activated after the power consumption reaches 5%. When Ts

motor is switched off intentionally. The drawing also shows how the reaction timer (Tr) becomes active after the limit has been exceeded. Tr is used to avoid alarms unless the power consumption has been greater than the limit for a certain time duration. The default reaction time is set to 100 ms from the factory, but it may be programmed as low as 10 ms from the keyboard. This very fast reaction time, which may be essential to a lot of applications, is possible only due to

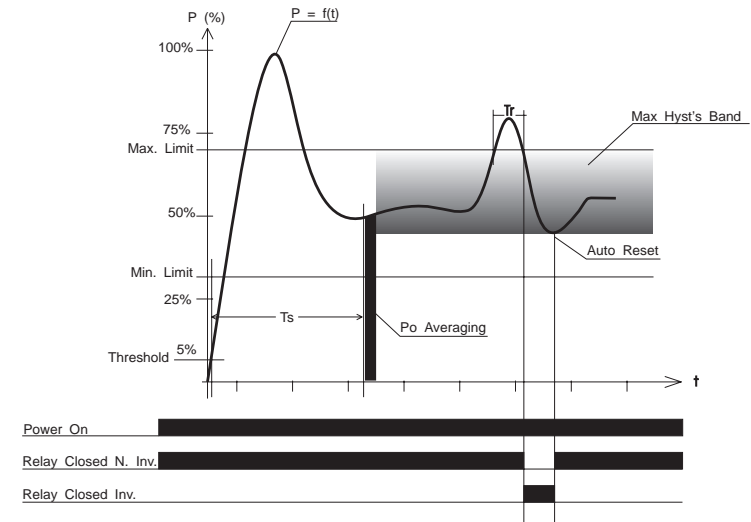

has expired then the limit, hysteresis, Tr etc. becomes active. If the power consumption drops below 5%, then the supervision is switched off again. When Ts expires, the idle power consumption is calculated as the average of the following 10 measurement cycles (200 ms at 50 Hz). In max. limit mode the idle power consumption may be subtracted from the current power consumption. This feature is enabled by the DIP. switch SW4. If the HPL410 is used as a min. limit protection unit, then a spare break-switch from the Motor Switch must be connected to the S2 input, otherwise an alarm is generated each time the

the extremely fast digital type of power measurement principle used in the HPL410. The figure also shows how a possible maximum hysteresis band would be placed relative to the maximum limit. Hysteresis is activated when an alarm is generated and the external reset is active (Auto-Reset mode). When the unit is used in the minimum limit mode, then the hysteresis band is placed above the minimum limit. A phase error (order or asymmetry) and a max. or min. alarm without Auto-Reset, forces the lout signal (4-20 mA) to 0 mA (possible remote alarm signalling).