

# Unipower<sup>®</sup> HPL110A

## Digital Power Monitor Installation and Operation

### True Motor Power Monitor with...

- High Trip Alarm
- Low Trip Alarm
- Digital Display
- Start and Trip Delay Timers

### Typical Applications

- Pumps
- Fans
- Conveyors
- Crushers and mixers
- Broken belt detection



# Contents

<b>1</b>	<b>System Overview</b>	3
<b>2</b>	<b>Functional Description</b>	4
<b>3</b>	<b>Typical Applications</b>	7
<b>4</b>	<b>System Configuration</b>	8
<b>5</b>	<b>Electrical Installation:</b>	10
	3-Phase Power Connection	
	1-Phase Power Connection	
	Alarm Relay States	
	Alarm Integration	
	Reset Function	
<b>6</b>	<b>Specifications:</b>	13
	Technical Specifications	
	DIP Switches	
<b>7</b>	<b>Mechanical Installation</b>	14
	HPL110A	
	Current Transformer	
<b>8</b>	<b>Programming</b>	16
<b>9</b>	<b>Troubleshooting</b>	19
<b>10</b>	<b>Set-Up Log Sheet</b>	20

**⚠ WARNING: Dangerous voltages are present in motor control panels; INSTALLATION MUST BE CARRIED OUT BY QUALIFIED PERSONNEL.**

**⚠ WARNING: Improper installation or programming can cause damage to the unit and/or result in ineffective protection and/or nuisance tripping.**

# 1 System Overview

The Unipower HPL110A advanced digital power monitor is a member of the Unipower family of “Intelligent Power-Control Units” designed for protection and control of motor driven mechanical systems.

The HPL110A measures true power consumption of 3-phase AC motors (single phase versions also available) and displays consumption as a percentage of selected power range. Power consumption (kW) is calculated from the formula:

$$P = \sqrt{3} \times U \times I \times \cos \varphi$$

The display shows power in units of %kW which represent the percentage of full load power range for the unit.

Control functions comprise two independent and programmable trip functions:

- Low Power Alarm** - for example, to stop a pump in the event of dry-running, and
- High Power Alarm** - for example, to stop a feeder when blocked.

The alarm functions activate a single alarm relay which may be used to control the motor being monitored; i.e. to trip a shut-down in the event of either a high or low power alarm.

The HPL110A may be configured to monitor any size motor either with the internal current transformer for applications up to 8A or with an external CT for applications above 8A.

The HPL110A provides consistent sensitivity across the complete motor load range making it ideal for low trip applications where amp meters are ineffective. In addition, the HPL110A measurement principle allows it to be used on non-sine shaped loads such as Variable Frequency Drives.

The digital design of the HPL110A including 3-key programming, 3 digit display, Max/Min Peak Hold, Program Lock and Power Down Alarm Block functions make it very easy to use.



# 2

## Functional Description

The Unipower HPL110A may be used either for monitoring applications - to protect process equipment - or for control applications - to control secondary process functions.

### Monitoring Example for Machinery Protection

A typical Power vs. Time graph for the HPL110A is shown in Figure 2.1 with the Y-axis showing power P in units of %kW and the X-axis showing time.

At time 0, mains power is turned on, the HPL110A unit is energized and the alarm relay changes state to the "on" condition.

At time 1, the motor is turned on and the load immediately surges due to the starting current inrush before settling to a steady value at time 4.5.

At time 8, this example shows power rising above the L1 Max. Limit which triggers an alarm resulting in the motor being switched off at time 9.5.

A continuation is shown starting at time 20 where the motor load drops such that it falls below the L2 Min Limit at time 22. An alarm is again triggered after the delay timer expires resulting in the motor again being shut down at time 23.

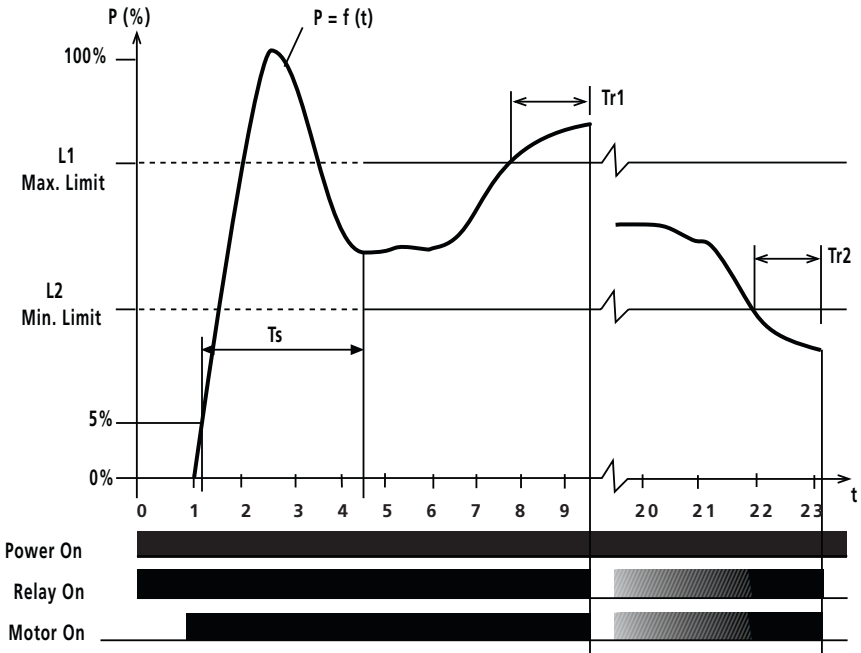

Figure 2.1

**The HPL110A functions in these examples are as follows:**

**P - Power %kW:** The display shows true power in units of % of full scale for the HPL110A as installed.

**Ts - Start Delay Timer:** Ts is used to delay the start of active monitoring until after the start surge is completed.

The HPL110A assumes that the motor is OFF when measured load - %kW - is below 5% full scale. The Ts timer starts when the load reaches 5% and monitoring is disabled for the duration of the Ts period. Ts is programmable in the range 0.1 to 99.9 seconds.

On conclusion of the Ts period, monitoring becomes active.

If P drops below 5%, monitoring is immediately disabled and a new Ts period will start as soon as load again reaches 5%.

**L1 - Max. Limit:** Max. alarm limit programmable in the range 5% to 100% / OFF and used in conjunction with the Tr1 Reaction Timer. A Max. Limit alarm is tripped if P exceeds L1 for a period Tr1.

**Tr1 - Reaction Timer:** Used in conjunction with the L1 Max. Limit and programmable in the range 0.0 to 99.9 seconds. Tr1 is time for which the P must remain above the L1 Max. Limit before an alarm is declared. If P falls below the L1 during the Tr1 timer period, the timer is re-set to zero.

**Note:** *if Tr1 is set to 0.0 seconds, actual reaction time will be one cycle or approx. 16 msec. at 60Hz and 20 msec. at 50Hz*

**L2 - Min. Limit:** Min. alarm limit programmable in the range OFF / 5% to 100% and used in conjunction with the Tr2 Reaction Timer. A Min. Limit alarm is tripped when P remains below the L2 Min. Limit for a period of time Tr2.

**Tr2 - Reaction Timer:** Used in conjunction with the L2 Min. Limit and programmable in the range 0.0 to 99.9 seconds. Tr2 is time for which the P must remain below the L2 Min. Limit before an alarm is declared.

**Δ - Max. Level:** If the Δ up arrow key is depressed while the HPL110A is in monitor mode, the display will show the maximum load - in %kW - experienced since the last Ts.

**∇ - Min. Level:** If the ∇ down arrow key is depressed while the HPL110A is in monitor mode, the display will show the minimum load - in %kW - experienced since the last Ts.

## Control Example

While monitoring for machinery protection is the primary application for the HPL110A, it is also suitable for simple two-point control regulation applications by using the Hysteresis function included in the unit.

A possible control example might be where the HPL110A is monitoring the power consumed to mix a slurry and the relay output is used to add liquid if the slurry becomes too viscous.

This is shown graphically in Figure 2.2. Power surges when the motor is switched on and the  $T_s$  function inhibits monitoring until the motor settles at time 2.5.

Once  $T_s$  is completed, the high power alarm becomes active and a hysteresis band (programmable) is shown under this alarm level. At time 5, the mixing power rises above the L1 Max. Limit and, after the  $Tr1$  trip delay times out, the alarm is activated and the relay switches.

In this example, the relay controls the addition of liquid to the slurry and the power gradually drops as liquid is added until at time 7, it has fallen below the hysteresis band for the L1 Max. Limit. At this point, the alarm relay is automatically reset and the addition of liquid is stopped.

Typical applications include the continuous control of mixing, crushing and grinding processes. Hysteresis is also available on the L2 Min. limit in the same manner (not shown).

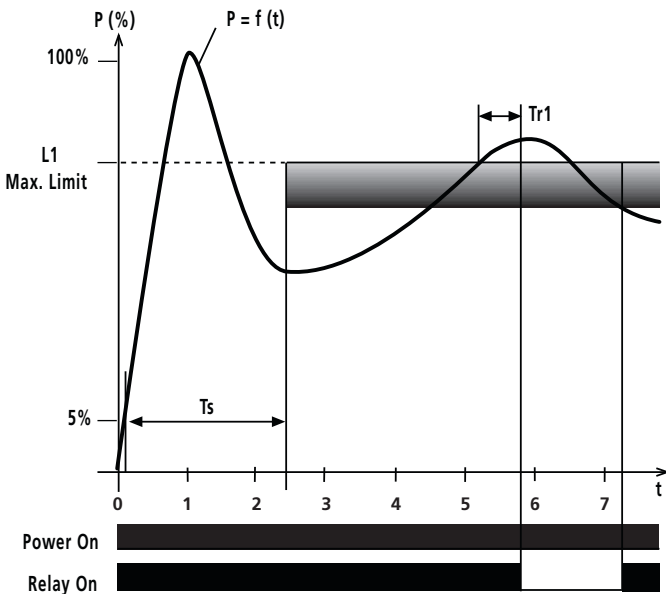

# 3

## Typical Applications

### Seal-less Centrifugal Pumps

These “positive pressure” pumps have a power curve which is proportional to flow rate. Power monitoring using the HPL110A, therefore, is very effective for ensuring the pump is running within the design minimum and maximum flow limits.

This is particularly true of seal-less pumps where dry-running can quickly result in damage or failure of the pump and containment system.

These situations are very effectively detected by the HPL110A as “low power” alarms and, being a true power monitor, the HPL110A is far more effective at detecting under-power situations than a current sensing relay.

### Positive Displacement Pumps

In the case of positive displacement pumps, flow rate is constant but excessive outlet restriction results in high pressure and high power. The HPL110A provides a simple, non-intrusive monitoring function which can be effectively used to protect against dead-heading.

Again, dry-running is detrimental to the pump and results in a low power condition which is also effectively monitored for with the HPL110A.

### Belt Breakage

The HPL110A can be used to immediately detect a low power conditions resulting from transmission chain or belt breakage and is far more sensitive to such “low power” conditions than a simple current sensor.

The HPL110A helps avoid the damage which is easily generated when part of a production line is malfunctioning.

### Feeder Blockage

The HPL110A can be used to immediately generate a max. kW alarm when a feeder mechanism is jammed or overloaded. Such applications would include belt or screw feeders, conveyors, etc. In many cases, the HPL110A can replace mechanical shear pins and are easier to set.

Many Other Applications exist including: Fans, Mixers, Crushers, Grinders, etc.

# 4

## System Configuration

The Unipower HPL110A measures voltage in all three legs of the 3-phase supply (or one leg and neutral for single phase versions) and current in one leg. The HPL110A has an internal current transformer with a measurement range of 8 Amps.

In configuring the HPL110A for a particular application, the voltage rating of the unit must match the mains supply being used and the effective current measured by the unit must be within its internal 8 Amp capacity.

### 4.1 VOLTAGE MATCHING:

From Table 4.1, ensure that the rated voltage for the HPL110A unit matches the mains voltage being used.

For single phase applications, an isolation transformer must always be used with a secondary voltage of 24V.

Catalog Number	Phase	Use for 50/60 Hz Mains Voltages
HPL110/220	3-Phase	208/220/230/240 VAC
HPL110/380	3-Phase	380/415 VAC
HPL110/460	3-Phase	460/480 VAC
HPL110/575	3-Phase	575/600 VAC
HPL110A/524	1-Phase	110/120 and 208/220/230/240 VAC

Figure 4.1

**Note:** The display full scale for the HPL110A is based on the nominal voltage of the unit; e.g. when using a nominal 220V unit at 208V, the display range will read 95% at full load (208/220 in %).

### 4.2 CURRENT MATCHING:

From the motor name plate, note the full load current in Amps. If full load amperage for the motor is 8 amps or less, an external current transformer is not required.

If the full load current is greater than 8 amps, then an external N/1 or N/5 current transformer must be used.

Refer to Table 4.2 for the appropriate selection of current transformer and current range setting for the HPL110A.

The HF3A current transformers specified in this table are low voltage, through-primary devices offered as accessories for the HPL110A product line; equivalent devices from other manufacturers may be substituted at user's discretion.



Full Load Amps	Current Transformer	Ratio Primary : Secondary	Primary Turns	HPL110 Range Setting	Effective Range Amps
1	Internal	1 : 1	1	1	1
3	Internal	1 : 1	1	3	3
5	Internal	1 : 1	1	5	5
8	Internal	1 : 1	1	8	8
10	HF3A,050/5	50 : 5	1	1	10
15	HF3A,050/5	50 : 5	2	3	15
25	HF3A,050/5	50 : 5	2	5	25
30	HF3A,050/5	50 : 5	1	3	30
50	HF3A,050/5	50 : 5	1	5	50
75	HF3A,075/5	75 : 5	1	5	75
100	HF3A,100/5	100 : 5	1	5	100
150	HF3A,150/5	150 : 5	1	5	150

Figure 4.2

**Note:** The two ranges given for full load ratings of 15 and 25 Amps require two primary wraps of the current transformer whereas all other ranges require a single through primary.



Figure 4.3

Figure 4.3 shows the HF3A current transformers with a single through primary hook-up and with two primary wraps. When taking multiple primary wraps on the HF3A current transformers, ensure that the wraps are wound to the sides and not across the top or bottom of the current transformer.

# 5

## Installation - Electrical

### 5.1 3-PHASE HOOK-UP

The HPL110A should be connected directly in front of the motor starter unit and downstream of the motor fuses and/or isolation breaker as shown in Figure 5.1.

An external current transformer with a secondary rating of 1 or 5 amps must be used if the rated full load motor current is in excess of 8 amps. Figure 5.1 shows correct installation using the internal current transformer (<8A), and using an external current transformer (>8A).

For correct readings, the current measurement must always be made on the L3 leg of the 3-phase supply. The direction of the current measurement, however, is not important.

**Power-Down Alarm Blocking:** When the motor is turned off, power drops to zero and a Min. Limit Alarm will be triggered if L2 is active. Figure 5.1 shows an auxiliary normally closed contact on the motor starter being used to short S2 to Gnd when the motor is off. This activates the S2 inhibit function which inhibits alarm functions and prevents a Min. Limit alarm on power down.

An alternative method of achieving the same result is available using the Min. Alarm Block function explained in Section 8.8; the S2 Inhibit solution described above is preferred and safer.

**Soft Starts and Frequency Inverters::** When using the HPL110A with a soft start or a motor driven by a frequency inverter, the HPL110A connections must be made directly in front of these devices.

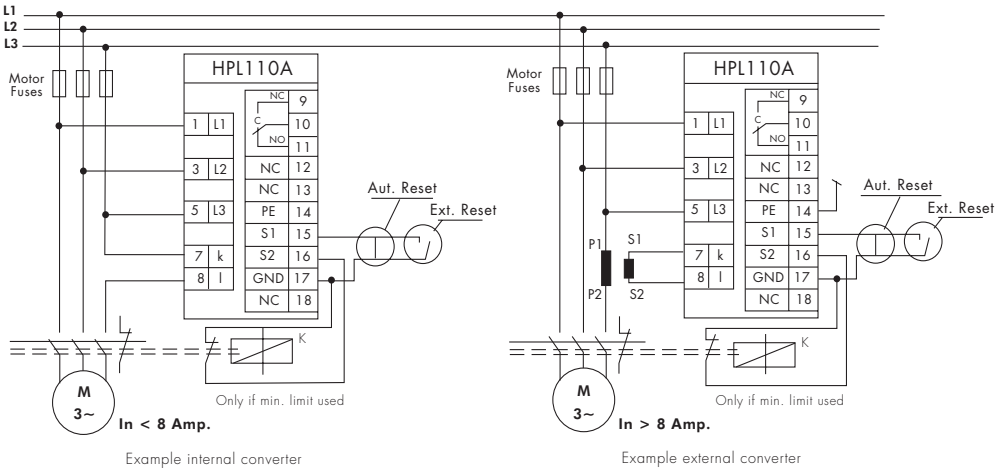

Figure 5.1

## 5.2 SINGLE PHASE HOOK-UP

Figure 5.2 shows correct connection for single phase mains units. The single phase version of the HPL110A requires a 24V secondary isolation transformer (supplied) with the L2 - Neutral side of the secondary grounded.

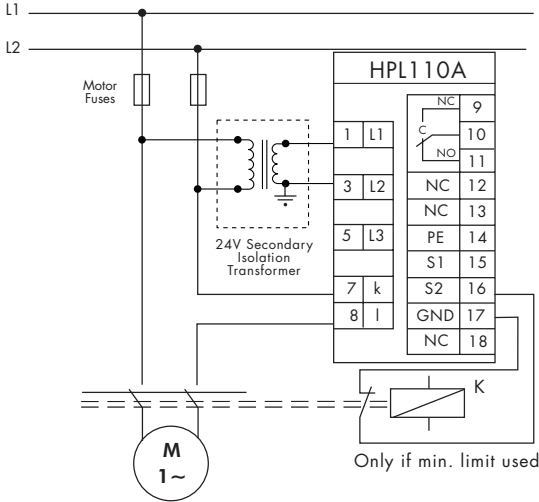

Figure 5.2

## 5.3 ALARM RELAY STATES

Figure 5.3 shows the states for the alarm relay. The relay is energized when the HPL110A is powered and is de-energized when an alarm state exists - fail safe operation. The Relay LED on the front panel is illuminated when the Relay is energized; this Relay LED, therefore, is on during normal operation and is switched off when an alarm occurs.

<b>Power</b>	Off	On	On
<b>Alarm Condition</b>	No	No	Yes
<b>Relay LED</b>	Off	On	Off
<b>Limit LED</b>	Off	Off	Flashing



Figure 5.3

**Note:** The HPL110A has a single alarm relay which is tripped by both a max. and/or a min. limit alarm.

## 5.4 ALARM INTEGRATION

In order for the HPL110A to stop the motor in the event of an alarm, the alarm relay (terminals 9, 10 and 11) must be integrated into the motor starter circuit such that it duplicates the effect of activating the STOP button.

One possibility is shown in Figure 5.4 where the NC relay contacts (terminals 9 and 10) are connected in series with the STOP button. When an alarm occurs, Terminals 9 and 10 change from closed to open which is equivalent to pressing the STOP button.

If an Alarm enunciation light is required, it can be connected between Terminal 11 and neutral to illuminate when an alarm state exists.

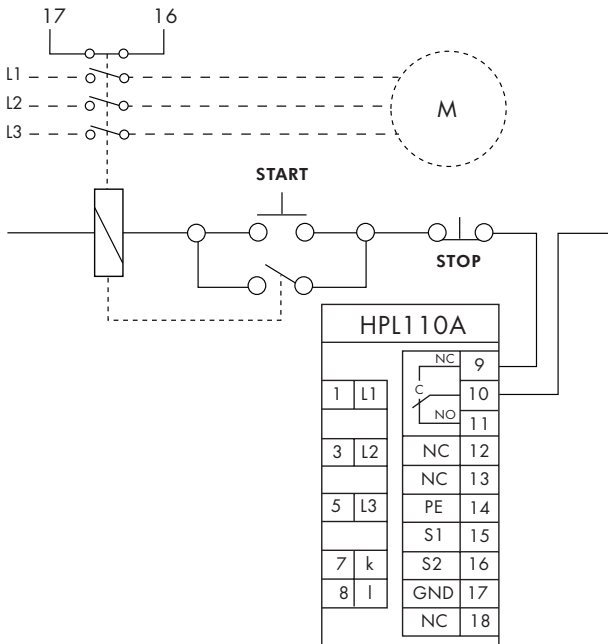

Figure 5.4

## 5.5 RESET FUNCTION

The HPL110A may be reset by any one of three methods:

**Manual Reset:** Depress the Reset key on the front panel.

**Remote Reset:** By wiring an Auxiliary reset button across contacts S1 to GND (pins 15 to 17) on the HPL110A, a remote reset may be achieved.

**Automatic Reset:** By wiring a jumper across contacts S1 to GND, the HPL110A operates in automatic reset mode with the Hysteresis function active; this is typically only used for two-point control applications and not for protection applications.

# 6 Specifications

## 6.1. TECHNICAL SPECIFICATIONS

### Electrical

**Voltage Range:** See unit for range

Standard ranges—

3 x 220, x 380, x 460, x 575

Also available—

1 x 24V for 110/220V single phase

### **Current Range:**

Internal - max. 8A

External - N/1 or N/5 converter

**Cos  $\phi$  Range:** 0  $\rightarrow$  1

### **Frequency Range:**

45  $\rightarrow$  65 Hz

### **Consumption:**

Supply voltage = measurement voltage, 2 VA

**Relay Output:** 250VAC/5Amp

### Mechanical

**Housing:** Noryl

**Mounting:** Panel mounting for  
2.64" x 2.64" cut-out (67 x 67 mm)  
Min. mounting depth 5" (125 mm)

**Protection Class:** IP54

**Terminals:** 12 AWG max., 20A  
7 in.lb tightening torque (0.8N.m)

**Operating Temperature Range:**  
+5  $\rightarrow$  +122°F (-15  $\rightarrow$  +50°C)

**Weight:** ~1lb (0.5 kg)

### **Dimensions:**

D 4.4" x B 2.85" x H 2.85"  
(D 112 x B 72 x H 72 mm)

### **Listing:**



CE mark to EN50081-1, 50082-2, 61010-1  
UL certified to UL508 (USA) and C22.2 No.14-M91  
(Canada) standards for Industrial Control Equipment

## 6.2 DIP SWITCHES

Access through hole  
in top face as shown.

### **Functions:**

DIP Sw. 1 "OFF" = Programming Enabled

DIP Sw. 1 "ON" = Programming Disabled  
(Protected)

DIP Sw. 2 "OFF" = Alarms Normal

DIP Sw. 2 "ON" = Special Power-Down  
Alarm Block Function  
Enabled, see 8.8,  
page 18

Access to DIP Switch



Figure 6.1

# 7

## Installation - Mechanical

### HPL110A Module

The HPL110A unit is designed to be mounted through a panel of an enclosure with the face exposed and the body protected within.

A square cut-out is required of 2.64" x 2.64" (67 x 67 mm), the HPL110A is installed through the cut-out and retained with fittings supplied.

A minimum depth of 5" (125 mm) will be required to allow space for the terminal fittings and wire bend at the rear of the unit.

The HPL110A face is sealed to IP54 standards.

The terminal connections are rated for 12 AWG (4mm<sup>2</sup>) wires max.

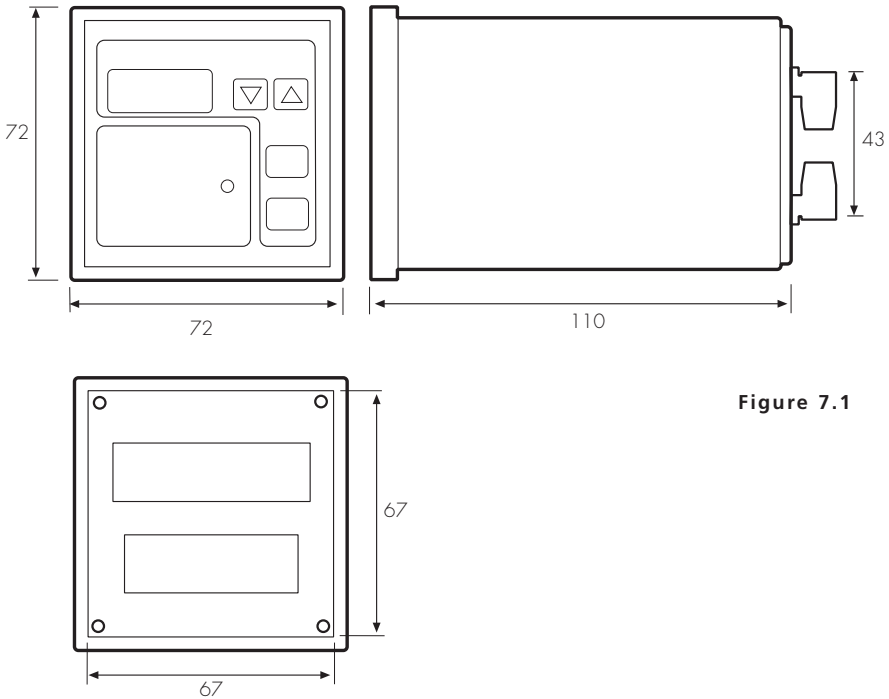

Figure 7.1

## Current Transformers

The optional HF3Axxx/x series current transformers may be mounted either directly to standard 35mm DIN rail, as shown on Page 9, using accessory 741B0231 - not included - or screwed directly to a panel using two M5 or #10 cap screws with accessory 741B0230/6 - not included - as shown in Fig. 7.2

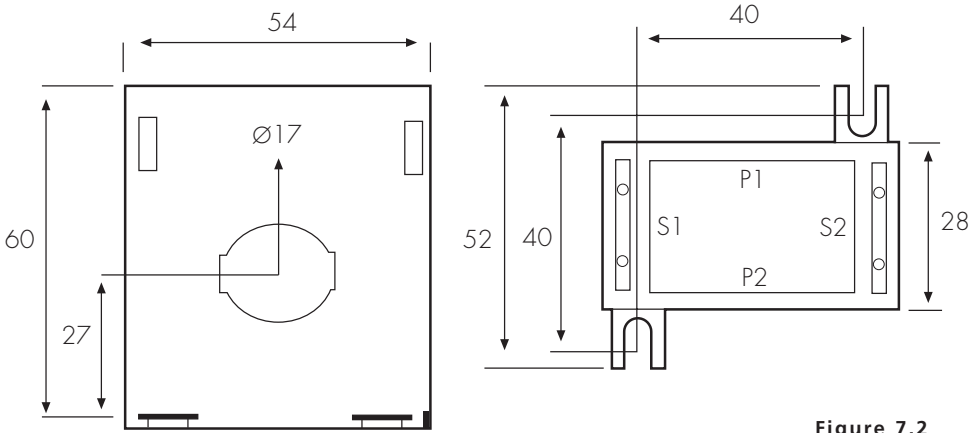

Figure 7.2

# 8

## Programming

The Modes and Programming ranges for the HPL110A are given in the Function Table below:

Mode	Function	Variable	▼	▲	Display	Default
Power=kW(%)	kW display	-	Min.Peak	Max.Peak	kW (%)	-
Max. Limit	Max.kW Limit	5-100%/off	Decrease	Increase	Off/Max.Limit (%)	80%
Min.Limit (%)	Min.kW Limit	Off/5-100%	Decrease	Increase	Off/Min.Limit (%)	20%
Start Timer(S)	Start Timer	0.1-99.9 Sec.	Decrease	Increase	Ts (Sec.)	2.0 Sec.
Reaction Timer(S)	Max.Alarm Delay	0.0-99.9 Sec	Decrease	Increase	Max. Tr (Sec.)	0.1 Sec.
Reaction Timer(S)	Min.Alarm Delay	0.0-99.9 Sec	Decrease	Increase	Min. Tr (Sec.)	0.1 Sec.
Hysteresis(%)	2 points regulation	2-50%	Decrease	Increase	Hysteresis (%)	10%.
Current Range(A)	Current Range	1,3,5,8 Amp.	Decrease	Increase	1,3,5,8	5 Amp.

The HPL110A is programmed using only three keys - MODE, ▲, ▼. The MODE key is used to select the variable to be programmed and the values are adjusted using the ▲, ▼ keys. The default state for the HPL110A on power up is kW[%] mode. If any key is continuously depressed, its action is repeated. When no key has been depressed for about 5 seconds, the mode reverts to kW[%] mode.

***The HPL110A is programmed in the following sequence:***

### 8.1 CURRENT RANGE

Depress the MODE key to select Current Range [A] mode. From Table 4.2, find the correct Current Range value for the unit as installed and enter this value using the ▲, ▼ keys.

### 8.2 CHOOSING LIMITS

The HPL110A may be programmed while running and it is useful to observe normal conditions in order to set the remaining parameters - Ts, L1, Tr1, L2 and Tr2.

To run the HPL110A before the limits have been set, first de-activate the high and low alarms by programming the L1 Max Limit to 101% and the L2 Min Limit to 0%. When a limit is de-activated, "OFF" is written in the display.

*Then start the motor and:*

- note time delay between pressing start button and stable display reading,
- load the system to max. normal operating load and press the ▲ key to note the max. allowable %kW value,
- load the system to min. normal operating load and press the ▼ key to note the min. allowable %kW value.



Use the values noted to set the remaining program parameters as described below.

### **8.3 TS: START TIMER**

The Ts Start Delay Timer is used to inhibit monitoring during the motor start-up surge. To determine the appropriate value for Ts, start the motor and observe how long - seconds - it takes for the HPL110A kW[%] display value to stabilize.

Depress the MODE key to select Start Timer [s] and then use the  $\Delta$ ,  $\nabla$  keys to adjust Ts value to a duration which is slightly longer than the settling time observed.

Since monitoring is inhibited while Ts is active, always try to set this parameter as low as possible without generating false alarms.

### **8.4 MAX. LIMIT TRIP POINT**

Using the Peak Detect function, run the system at its minimum load condition and observe the max. normal reading by depressing the  $\Delta$  key.

Set the Max. Limit value a few units higher than this value by depressing the MODE key to select Max. Limit [%] and then use the  $\Delta$ ,  $\nabla$  keys to adjust.

### **8.5 MIN. LIMIT TRIP POINT**

Again using the Peak Detect function, run the system at its minimum load condition and observe the min. normal reading by depressing the  $\Delta$  key.

Set the Min. Limit value a few units lower than this value by depressing the MODE key to select Min. Limit [%] and then use the  $\Delta$ ,  $\nabla$  keys to adjust.

### **8.6 REACTION TIMER SETTING**

The HPL110A has independent Reaction Timers for both the Max. Limit alarm and Min. Limit alarm which delay the alarm response when running outside the programmed limits. Their purpose is to reduce false alarms due to normal process fluctuations.

Both Reaction Timers should be set to the lowest value which does not result in false tripping.

The default values of 0.1 sec. will be good starting points for applications requiring rapid response, e.g. blockage detection on conveyors. For process applications such as pumps and mixing, longer Tr values - 1 to 2 sec. - will probably be more appropriate.

To set Reaction Time, depress the MODE key to select Reaction Timer [s] and Max. Limit [%] and then use the  $\Delta$ ,  $\nabla$  keys to adjust for Max. Limit Reaction Time.

Depress the MODE key again to select Reaction Timer [s] and Min. Limit [%] and then use the  $\Delta$ ,  $\nabla$  keys to adjust for Min. Limit Reaction Time.

## 8.7 RESPONSE TEST

A system response test should now be carried out to ensure that the HPL110A correctly stops the motor in the event of an alarm. To do this, run the system under normal conditions - no alarm should occur - and then depress the MODE key to select Max. Alarm [%] mode.

While in Max. Alarm [%] mode, use the  $\Delta$ ,  $\nabla$  keys to adjust the alarm limit to a value which is lower than normal running.

Use the MODE key to return to Power = kW [%] mode and wait. The Reaction Timer LED should illuminate and, once the reaction time has expired, a Max. Limit alarm should be triggered.

When the Max. Limit alarm triggers, the motor should stop.

## 8.8 DIP SWITCH FUNCTIONS

**Program Lock:** Once the HPL110A has been programmed, accidental changes may be prevented by turning the PROGRAM LOCK function on. To do this, switch DIP Switch 1 to the "ON" position, see section 6.2 for access.

When Program Lock is "ON", all setting values may be viewed but not changed. The Reset button, however, remains functional.

**Power-Down Alarm Block:** If using the HPL110A with an active L2 Min. Alarm, then it is advised to use the S2-GND inhibit function described in Section 5.1 to prevent false Min. Alarms when the motor is switched off.

If this is impractical, then the Power-Down Alarm Block function will prevent a min alarm from being declared if measured power falls below 5% of full load within the Tr2 trip delay value.

To select Power-Down Block function, set DIP Switch 2 to the "ON" position.

## 8.9 CONVERTING %KW TO ENGINEERING UNITS.

If it is necessary to set alarm limits in units of HP or kW or Torque, please refer to your supplier or directly to WEN Technology for assistance. All set-up information on the Set-Up Log Sheet - see back cover - will be required with the Max. and Min. Limit values required given in the desired units.

## 9 Trouble Shooting

Symptom	Suggestion
No Display	HPL110A is not getting power, check mains electrical connection
Display stays at “000” with motor running	HPL110A is not receiving a current signal, check that full L3 current is flowing into Terminal 7 and back out of Terminal 8 or from Secondary Terminals—S1 and S2—of current transformer, if used.
Max. Limit alarm trips immediately when pump is turned on	First check that Max. Limit setting is correct, then check that the Ts Start Timer setting is sufficiently long. Either increase L1 Max. Limit or TS Start Timer as appropriate.
Nuisance alarms during normal operation	First check that alarm values are correct. If nuisance alarms persist, increase the Tr Reaction Timer associated with the nuisance alarm.
Alarm trips but motor does not stop	Check integration of the HPL110A alarm relay with the motor starter.  Verify that the HPL110A relay is switching correctly.
Min. Limit alarm trips when motor is switched off	This is normal when using a Min. Limit alarm function. To correct, either implement the S2 alarm inhibit as described in Section 5.1 Power-Down Alarm Blocking or activate the Min. Alarm Block function described in section 8.8.
Display shows “100” during normal operation	HPL110A current range is saturating, check settings for Current Range against the motor ratings and correct as necessary.  HPL110A voltage rating is too low, check and install correct HPL110A model.  Motor is undersized.
Display decreases when load increases or vice versa	Check electrical connection and ensure that the L3 leg of the mains supply is connected to L3 - terminal 5 - and also used for the K-L current taps - terminals 7 and 8.



# Set-Up Log Sheet

## Application

Description \_\_\_\_\_

## Motor

Model \_\_\_\_\_

Full Load Power \_\_\_\_\_  kW  HP

Rated Full Load Current \_\_\_\_\_ A

Rated Mains Voltage \_\_\_\_\_ V

Mains Frequency  60 Hz  50 Hz

Phase  3-Phase  1-Phase

Rated Efficiency \_\_\_\_\_ %

## Unipower®

HPL110A Model HPL110A/xxx  220  380  460  575  S24

Current Transformer  None  50/5  75/5  100/5  150/5

Turns through CT  1x  2x

## Program

Current Range (A)  1  3  5  8

Start Time (S) \_\_\_\_\_ S

Max. Limit (%) \_\_\_\_\_ %

Reaction Timer (S) - Max \_\_\_\_\_ S

Min. Limit (%) \_\_\_\_\_ %

Reaction Timer (S) - Min \_\_\_\_\_ S

Program Lock  On  Off

Min. Alarm Block  On  Off

Software Version: 3.0

Document Number: WT99H001

© 1999 Wen Technology, Inc., Raleigh, NC USA



8411 Garvey Drive / Suite 117  
Raleigh, North Carolina 27616  
(919) 954-1004 / Fax (919) 954-1009  
www.wentec.com