

Examples.

The examples below shows the HPL425 used as a Max. load protection unit. When a Max. (1) limit is exceeded the Max. relay (1) is toggled and when the Max. (2) limit is exceeded the Min. relay (2) changes state. The drawing does not show how the alarm relay is used in the actual protection scheme (application specific). The alarm must be reset, either using the reset key located at the front panel or from the external reset input S1 or S2. S1 is used to reset Max. (1) alarms and S2 is the Max. (2) alarm reset. For motors, where the current exceeds 8 Amp., an external current converter N/1 or N/5

must be inserted as shown below. In these examples the HPL425 is mounted directly at the motor-switch after the fuses. If the input S1 and Gnd is shorted (Auto-Reset 1) or S2 and Gnd (Auto-Reset 2), the alarm activates the hysteresis function implementing a two-point regulation. This is for instance used in a grinding mill where the HPL425 measures the power consumption of the mill, but the relay output controls the feeder mechanism (belt, screw etc).

Note!!! An external current converter must always be mounted in the L3-phase for correct measurements. The converter polarity is not important.

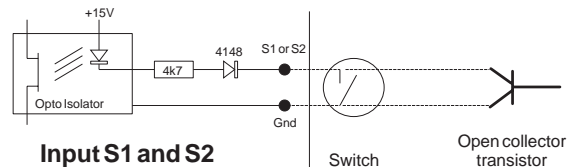
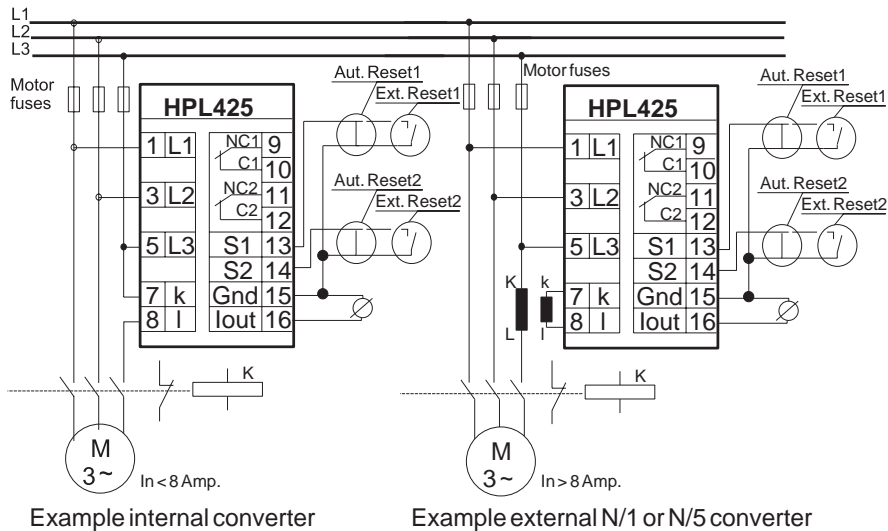

If you need further information about the HPL-family of **Intelligent Power-Control Units** and its ability to solve your problems, please do not hesitate to contact your distributor.

WENtechnology
Raleigh, NC, USA
(919) 954-1004 www.wentec.com

Unipower

HPL425
Version 4.0

Technical Information

English Edition

Technical Specification

Electrical

Voltage Range

See technical info on the unit.
Also Available:
3 x 120 VAC -> 3 x 575 VAC

Current Range

Internal: max. 8 A.
External: N/1 or N/5 converter.

Cosφ Range: 0-1.

Frequency Range: 45-65 Hz.

Consumption

Supply = measuring voltage, 3 VA.

Relay spec.: 240 VAC/5 Amp.

Analog Output

4-20 mA, 0-400 Ohm, electrically isolated from the measuring system.

Mechanical

Housing

Makrolon 8020 (30% GV), UL94V-1 (house).

Makrolon 2800, UL94V-2 (connector + front).

Mounting

Snap-on construction for 35mm DIN rail mounting or panel mounting.

Protection Class

IP40 (house).

IP20 (connector).

Temperature Range: -15 - +50 °C.

Weight: Approximately 500g.

Dimensions

D 110 x W 56 x H 75 mm.

Terminal tight. torque: 7lbs/in, 0.79Nm

Use 60/75 copper (CU) wire only

CE mark to:

EN50081-1, EN50082-2, EN61010-1

UL certified:

UL 508 - Industrial Control Equipment

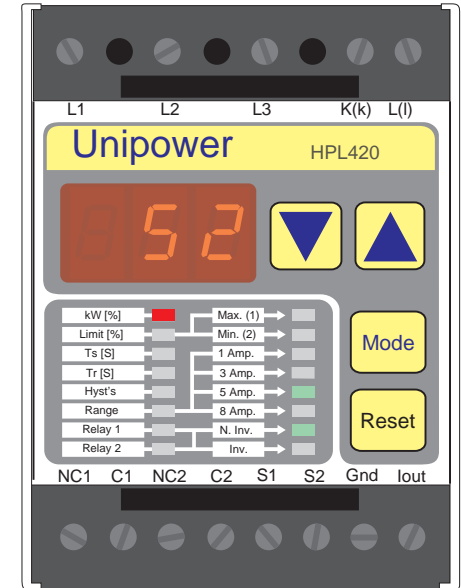

THE CONCEPT

The Unipower HPL425 is a member of a family of **"Intelligent Power-Control Units"**. The unit measures true power-consumption and shows the consumption as a percentage of the selected power-range. The power-consumption (kW) is calculated from the following formula:

$$P = \sqrt{3} \times U \times I \times \text{Cos}\phi$$

The primary function of the unit lies in the supervision and control of machinery driven by 3-phased AC-motors. The HPL425 integrates two Max. kW limit detectors plus the support functions necessary to establish the efficient and compact supervision or regulation of various types of machinery such as pumps, ventilators and conveyer belts. As well as the support functions Ts, Tr, hysteresis etc. the HPL425 has a built in current converter that works up to 8 Amp.

Programming & Display.

Mode	Function	Parameter	Min. Peak	Max. Peak	Display	Default
[kW] %	Normal Mode		Min. Peak	Max. Peak	kW [%]	
Limit [%]	Max. (1) limit	5-100%	Decrease	Increase	Limit [%]	80%
Limit [%]	Max. (2) limit	5-100%	Decrease	Increase	Limit [%]	70%
Ts[S]	Start Delay	0.1-25.0 Sec.	Decrease	Increase	Ts [Sek]	2.0 Sec.
Tr[S]	Max. 1 Alarm Reaction	0.0-25.0 Sec.	Decrease	Increase	Tr [Sek]	0.1 Sec.
Tr[S]	Max. 2 Alarm Reaction	0.0-25.0 Sec.	Decrease	Increase	Tr [Sek]	0.1 Sec.
Hyst's	Max. 1 Hysteresis	2-50%	Decrease	Increase	Hyst's [%]	10%
Hyst's	Max. 2 Hysteresis	2-50%	Decrease	Increase	Hyst's [%]	10%
Range	Current Range	1, 3, 5, 8 Amp.	8 --> 1	1 --> 8	"Cur"	5 Amp.
Relay 1	Relay 1 Polarity	N. Inv./Invert.	N.Inv<-->Inv	N.Inv<-->Inv	"Pol"	N. Inverted
Relay 2	Relay 2 Polarity	N. Inv./Invert.	N.Inv<-->Inv	N.Inv<-->Inv	"Pol"	N. Inverted

The HPL425 is programmed by the use of only three keys located on the front panel. The mode key is used to switch the display from showing kW [%] to display one of ten programmable parameters. All the parameters and their programming ranges are listed in the function table above. The red mode LED in combination with the two red Max. and Min. LED's are used to show which parameter may be altered. When a parameter has been selected by the mode key, the value may be altered by the two arrow-keys. Note that the function of the keys is repeated if held down continuously. Parameters are stored in EEPROM. When no key has been activated for about 5 seconds the display returns to the kW [%] position (Normal Operation). When the Dip. Sw. 1 is 'On' the unit is protected against programming; but it is still possible to display current settings.

LED Usage	
Max. Alarm	Max. LED flashing
Min. Alarm	Min. LED flashing
Start Delay	Ts LED lit
Alarm Delay	Tr LED lit
Relay 1 Closed	Relay 1 LED lit
Relay 2 Closed	Relay 2 LED lit

Phase Error	Display
Phase order L1 L3 L2	PH 1 (flashing)

DIP Switch Usage		
SW 1	Unit protected	ON
SW 2	Phase orders sup..	ON
SW 3	Not Used	OFF
SW 4	Not Used	OFF

The Phase order supervision generates an alarm if the three phases L1, L2 and L3 have been reversed. A phase error toggles the relay in exactly the same way as a Max. limit alarm and the display shows which type of error has occurred. A phase error is automatically reset when it has been corrected. During a phase error the 4-20 mA signal lout is set to 0 mA (possible remote alarm signalling).

Dip. Switch Access.

1. Disconnect the Mains Power.
2. Remove the front plate. (Use a small screwdriver).
3. Change the switch settings and assemble the unit again.

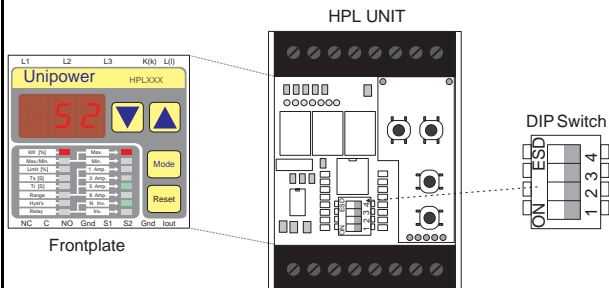

Important notice:

HPL425 is a customer specified unit which is based on HPL420. The unit uses the HPL420 frontplate but shows HPL425 during startup. Since the HPL425 has two Max.-limits and the front plate shows a Max. and a Min. limit, the Max. (2) limit is shown as Min. limit on the frontplate.

**i.e. Max. (1) limit = Max (1)
Max. (2) limit = Min (2)**

Function.

The drawing below shows a typical AC-motor power consumption curve (ex. pump) immediately after power has been applied to the motor. The programmable start timer (Ts) is used to filter out from the protection/regulation cycle the large peak power consumption generated by the motor when starting. The Ts delay function is activated

100 ms from the factory, but it may be programmed as low as 10 ms from the keyboard. This very fast reaction time, which may be essential to a lot of applications, is possible only due to the extremely fast digital type of power measurement principle used in the HPL425. The figure also shows how a possible hysteresis band would be placed relative to the limits. Hysteresis is activated when an alarm is generated and the exter-

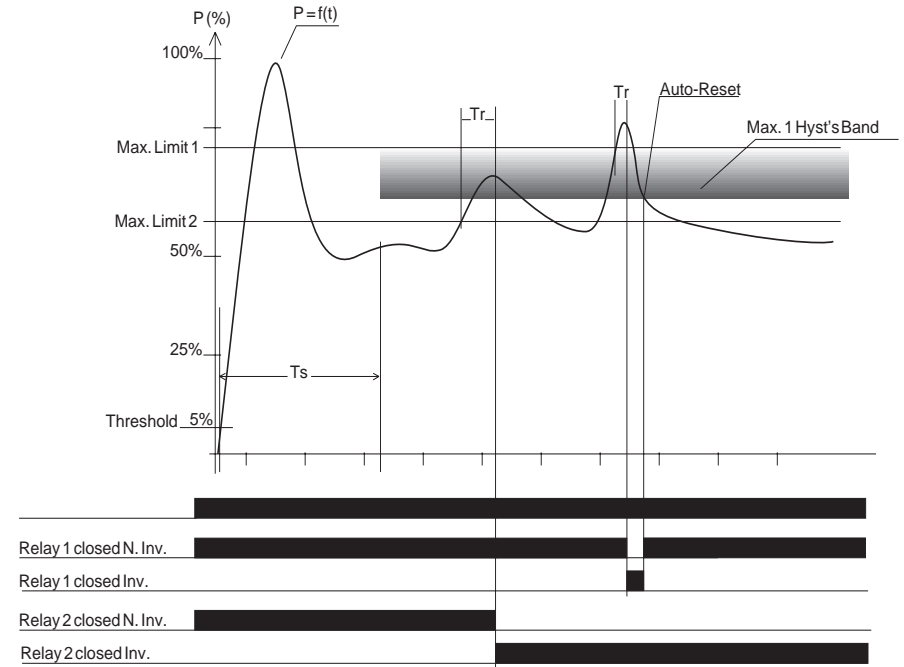

after the power consumption reaches 5%. When Ts expires, the limit, hysteresis, Tr etc. become active. If the power consumption drops below 5%, the supervision is switched off again. The drawing also shows how the reaction timer (Tr) becomes active after the limit has been exceeded. Tr is used to avoid alarms unless the power consumption has been greater than the limit for a certain time duration. The default reaction time is set to

nal reset (S1 or S2) is active (Auto-Reset mode). A phase order error and a Max. (1) or Max. (2) alarm, without Auto-Reset, forces the lout signal (4-20 mA) to 0 mA (possible remote alarm signalling).