

## Examples.

The examples below show the HPL426 used as a Max. load protection unit. When a Max.(1) limit is exceeded the Max. relay (1) is toggled and when the Max.(2) limit is exceeded the Max.(2) relay (2) changes state. The input S2 is used to select which limit that should be active. When S2 is open, the Max.(2) limit is active and when it is closed the Max.(1) limit becomes active. When S2 changes state a new start delay Ts is activated. The drawing does not show how the alarm relay is used in the actual protection scheme (application specific). The alarm must be reset, either using the reset key located on the front panel or from the external reset

input, S1. For motors, where the current exceeds 8 Amp., an external N/1 or N/5 current converter must be inserted as shown below. In these examples the HPL426 is mounted directly at the motor-switch after the fuses. If the input S1 and Gnd are shorted (Auto-Reset), the alarm activates the hysteresis function implementing a simple two-point regulation. This is for instance used in a grinding mill where the HPL426 measures the power consumption of the mill, but the relay output controls the feeder mechanism (belt, screw etc).

**Note!!! An external current converter must always be mounted in the L3-phase for correct measurements. The converter polarity is not important.**

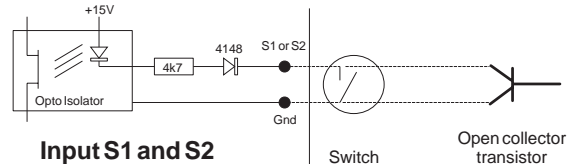
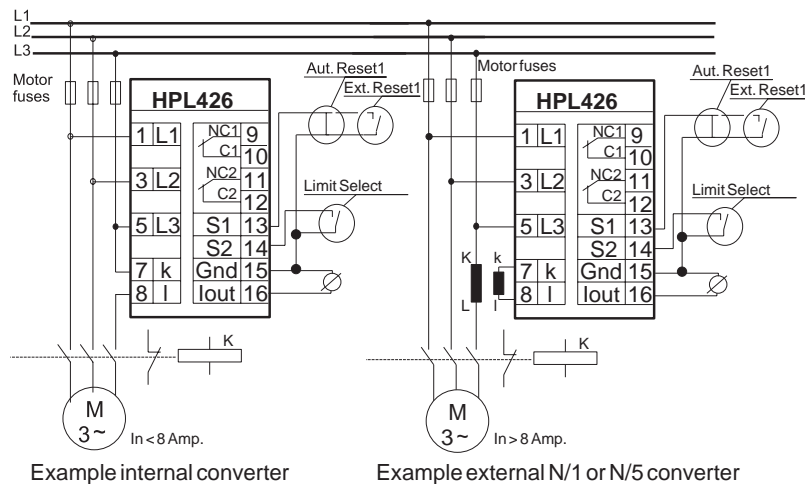

If you need further information about the HPL-family of **Intelligent Power-Control Units** and its ability to solve your problems, please do not hesitate to contact us.

**WEN**technology  
Raleigh, NC, USA  
(919) 954-1004 [www.wentec.com](http://www.wentec.com)

# Unipower

HPL426  
Version 4.0

Technical Information

English Edition

## Technical Specification

### Electrical

#### Voltage Range

See technical info on the unit.  
Also Available:  
3 x 120 VAC -> 3 x 575 VAC

#### Current Range

Internal: max. 8 A.  
External: N/1 or N/5 converter.

#### Cosφ Range: 0-1.

#### Frequency Range: 45-65 Hz.

#### Consumption

Supply = measuring voltage, 3 VA.

#### Relay spec.

240 VAC/5 Amp.

#### Analog Output

4-20 mA, 0-400 Ohm, electrically isolated from the measuring system.

### Mechanical

#### Housing

Makrolon 8020 (30% GV), UL94V-1 (house).  
Makrolon 2800, UL94V-2 (connector + front).

#### Mounting

Snap-on construction for 35mm DIN rail mounting or panel mounting.

#### Protection Class

IP40 (house).  
IP20 (connector).

#### Temperature Range: -15 - +50 °C.

#### Weight: Approximately 500g.

#### Dimensions

D 110 x W 56 x H 75 mm.

Terminal tight. torque: 7lbs/in, 0.79Nm

Use 60/75 copper (CU) wire only

#### CE mark to:

EN50081-1, EN50082-2, EN61010-1

#### UL certified:

UL 508 - Industrial Control Equipment



## THE CONCEPT

The Unipower HPL426 is a member of a family of **"Intelligent Power Control Units"**. The unit measures true power-consumption and shows the consumption as a percentage of the selected power-range. The consumption (kW) is calculated from the following formula:

$$P = \sqrt{3} \times U \times I \times \text{Cos}\phi$$

The primary function of the unit lies in the supervision and control of machinery driven by 3-phased AC-motors (often two speed motors with switchable number of poles). The HPL426 integrates two Max. kW limit detectors plus the support functions necessary to establish the efficient and compact supervision or regulation of various types of machinery such as pumps, ventilators and conveyor belts. As well as the support functions Ts, Tr, hysteresis etc. the HPL426 has a built in current converter that works up to 8 Amp.

## Programming & Display.

Mode	Function	Parameter	Min. Peak	Max. Peak	Display	Default
[kW] %	Normal Mode		Min. Peak	Max. Peak	kW [%]	
Limit [%]	Max. Limit 1	5-100%	Decrease	Increase	Limit [%]	80%
Limit [%]	Max. Limit 2	5-100%	Decrease	Increase	Limit [%]	60%
Ts[S]	Start Delay	0.1-25.0 Sec.	Decrease	Increase	Ts [Sek]	2.0 Sec.
Tr[S]	Max. 1 Alarm Reaction	0.0-25.0 Sec.	Decrease	Increase	Tr [Sek]	0.1 Sec.
Tr[S]	Max. 2 Alarm Reaction	0.0-25.0 Sec.	Decrease	Increase	Tr [Sek]	0.1 Sec.
Hyst's	Max. 1 Hysteresis	2-50%	Decrease	Increase	Hyst's [%]	10%
Hyst's	Max. 2 Hysteresis	2-50%	Decrease	Increase	Hyst's [%]	10%
Range	Current Range	1, 3, 5, 8 Amp.	8 --> 1	1 --> 8	"Cur"	5 Amp.
Relay 1	Relay 1 Polarity	N. Inv./Invert.	N.Inv-->Inv	N.Inv-->Inv	"Pol"	N. Inverted
Relay 2	Relay 2 Polarity	N. Inv./Invert.	N.Inv-->Inv	N.Inv-->Inv	"Pol"	N. Inverted

The HPL426 is programmed by the use of only three keys located at the front panel. The mode key is used to switch the display from showing kW [%] to display one of ten programmable parameters. All the parameters and their programming ranges are listed in the function table above. The red mode LED in combination with the two red Max. and Min. LED's are used to show which parameter may be altered. When a parameter has been selected by the mode key, the value may be altered by the two arrow-keys. Note that the function of the keys is repeated if held down continuously. Parameters are stored in EEPROM. When no key has been activated for about 5 seconds the display returns to the kW [%] position (Normal Operation). When the Dip. Sw. 1 is 'On' the unit is protected against programming; but it is still possible to display current settings.

LED Usage	
Max. Alarm	Max. LED flashing
Min. Alarm	Min. LED flashing
Start Delay	Ts LED lit
Alarm Delay	Tr LED lit
Relay 1 Closed	Relay 1 LED lit
Relay 2 Closed	Relay 2 LED lit

Phase Error	Display
Phase order L1 L3 L2	PH 1 (flashing)

DIP Switch Usage		
SW 1	Unit protected	ON
SW 2	Phase order sup.	ON
SW 3	Not used	OFF
SW 4	Separate current range	ON

The Phase order supervision generates an alarm if the three phases L1, L2 and L3 have been reversed. A phase error toggles the relay in exactly the same way as a Max. limit alarm and the display shows which type of error has occurred. A phase error is automatically reset when it has been corrected. During a phase error the 4-20 mA signal lout is set to 0 mA (possible remote alarm signalling).

## Dip. Switch Access.

1. Disconnect the Mains Power.
2. Remove the front plate. (Use a small screwdriver).
3. Change the switch settings and assemble the unit again.

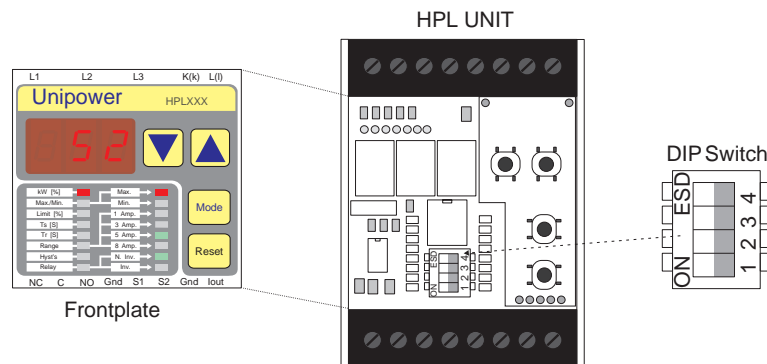

## Function.

The drawing below shows a typical AC-motor power consumption curve (ex. pump) immediately after power has been applied to the motor. The programmable start timer (Ts) is used to filter out from the protection/regulation cycle the large peak power consumption generated by the motor when starting. The Ts delay function is activated

activate hysteresis. When input S2 is open, the Max. 2 limit is activated and when it is closed the Max. 1 limit is enabled. Each time S2 changes state the supervision is switched off and a new Ts (start-delay) is initiated. A phase error (order or asymmetry) and a Max. alarm, without Auto-Reset, forces the lout signal (4-20 mA) to 0 mA (possible remote alarm signalling).

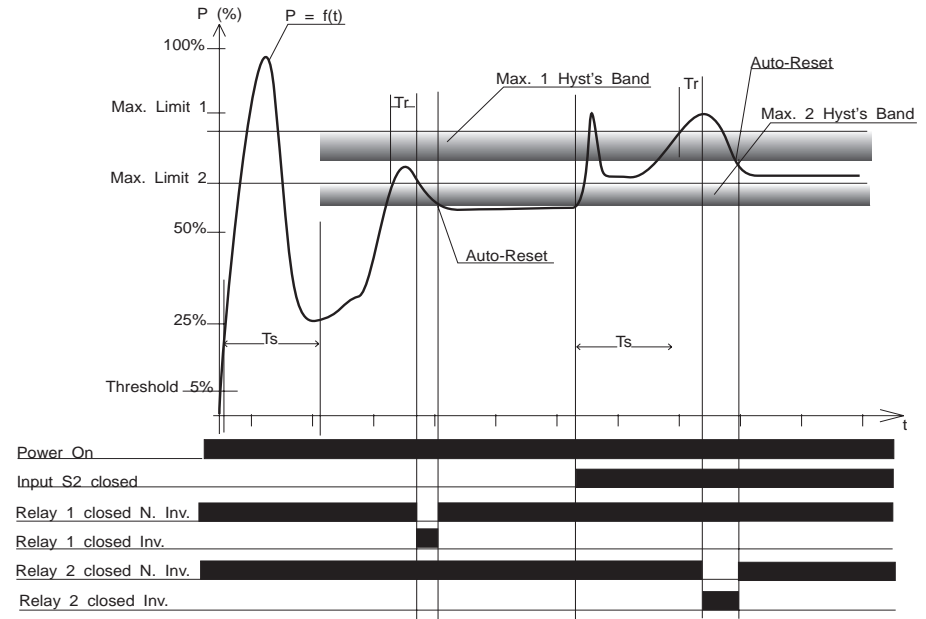

after the power consumption reaches 5%. When Ts has expired then the limit, hysteresis, Tr etc. become active. If the power consumption drops below 5% then the supervision is switched off again. The drawing also shows how the reaction timer (Tr) becomes active after the limit is exceeded. Tr is used to avoid alarms unless the power consumption has been greater than the limit for a certain time duration and thus may help to increase noise immunity. The figure also shows how a possible hysteresis band would be placed relative to the corresponding limit. Hysteresis is activated when an alarm is generated and the external reset is active (Auto-Reset mode). The input S1 is used to reset both types of alarms or to

## Separate current range for each limit:

**Ex.** A two speed motor consumes 20A in speed 1 and 5A in speed 2. An external 30/5A C.T. is used. The current range for speed 1 is 5A and the unit shows 0-100% corresponding to 0-30A at cosφ 1 and nominal voltage. The current range for speed 2 is 1A and the unit shows 0-100% corresponding to 0-6A at cosφ 1 and nominal voltage. SW4 must be ON in order to use separate current range for each limit. Using the "mode" key choose "Range" and the Limit 1 LED is lit. Now choose the current range (1, 3, 5 or 8A) for limit 1 using the arrow keys. Pressing the "mode" key the Limit 2 LED is lit and the current range for this limit is chosen the same way.