

## Examples.

The examples below show the HPL440 used as a conveyor protection unit with automatic reversal. The relay-contacts A1 and B1 are used for improved security only and the On/Off switch must be implemented according to usual design rules. If a blocking condition has not been removed after Rev.[n] attempts or a blocking occurs in the reverse direction, the machinery is stopped, the Opto-output S2 is deactivated, and the signal lout is set to 0 mA (remote signalling of non-recoverable blocking).

This condition is reset by the reset key on the front panel or from the external reset, S1. NOTE!: If the On/Off switch is left in the "On" position the machinery will run forward immediately after resetting. For security reasons the main supply should be removed from the machinery and the fault cleared. In these examples the HPL440 is mounted directly at the motor-switch after the fuses. This enables the use of phase order supervision. If the motor current exceeds 8 Amp., an external N/1 or N/5 current converter must be mounted as shown in the second example below.

**Note!!! An external current converter must always be mounted in the L3-phase for correct measurements. The converter polarity is not important.**

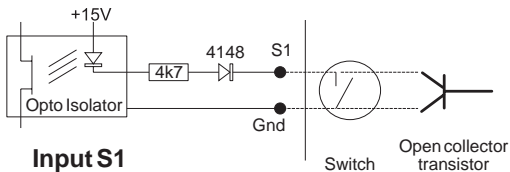
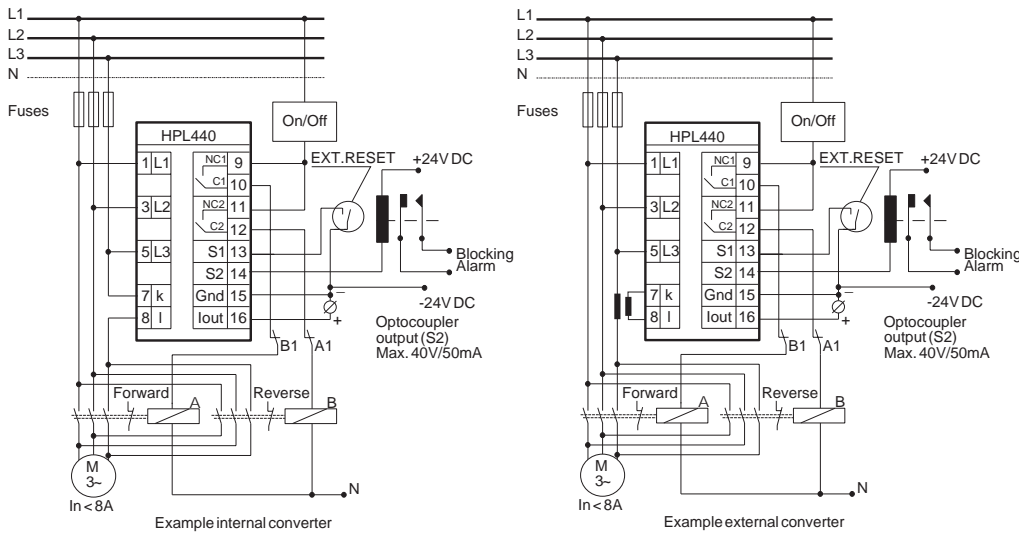

Input S1

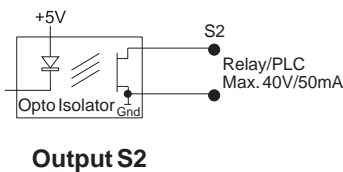

Output S2

If you need further information about the HPL-family of **Intelligent Power-Control Units** and its ability to solve your problems, please do not hesitate to contact your distributor.

**WEN**technology  
Raleigh, NC, USA  
(919) 954-1004 [www.wentec.com](http://www.wentec.com)

# Unipower

HPL440  
Version 4.0

Technical Information

English Edition

## Technical Specification

### Electrical

#### Voltage Range

See technical info on the unit.  
Also Available:  
3 x 120 VAC -> 3 x 575 VAC

#### Current Range

Internal: max. 8 A.  
External: N/1 or N/5 converter.

#### Cosφ Range: 0-1.

#### Frequency Range: 45-65 Hz.

#### Consumption

Supply = measuring voltage, 3 VA.

#### Relay spec.: 240 VAC/5 Amp.

#### Analog Output

4-20 mA, 0-400 Ohm, electrically isolated from the measuring system.

### Mechanical

#### Housing

Makrolon 8020 (30% GV), UL94V-1 (house).  
Makrolon 2800, UL94V-2 (connector + front).

#### Mounting

Snap-on construction for 35mm DIN rail mounting or panel mounting.

#### Protection Class

IP40 (house).  
IP20 (connector).

#### Operating Temperature Range

-15 - +50 °C.

#### Weight: Approximately 500g.

#### Dimensions

D 110 x W 56 x H 75 mm.

Terminal tight. torque: 7lbs/in, 0.79Nm

Use 60/75 copper (CU) wire only

#### CE mark to:

EN50081-1, EN50082-2, EN61010-1

#### UL certified:

UL 508 - Industrial Control Equipment

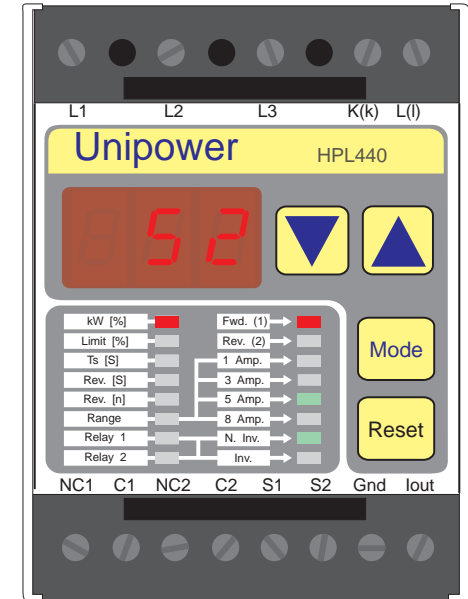

## THE CONCEPT

The Unipower HPL440 is a member of a family of **"Intelligent Power-Control Units"**. The unit measures true power-consumption and shows the consumption as a percentage of the selected power-range. The power-consumption (kW) is calculated from the following formula:

$$P = \sqrt{3} \times U \times I \times \text{Cos}\phi.$$

The primary function of the unit lies in the supervision and control of machinery driven by 3-phased AC-motors. The HPL440 is specifically developed for load protection of conveyance machinery. When a conveyor transport is blocked the HPL440 reverses the transport direction in order to automatically recover the fault. The number of reversals and the reverse-time are programmable from the front panel.

## Programming & Display.

Mode	Function	Parameter	Decrease	Increase	Display	Default
[kW] %	kW display		Min. Peak	Max. Peak	kW [%]	
Limit [%]	Max. kW Limit	5-100%	Decrease	Increase	Limit [%]	80%
Ts[S]	Start Delay	0.1-25.0 Sec.	Decrease	Increase	Ts [Sek]	2.0 Sec.
Rev.[S]	Reversal Timer	0.1-25.0 Sec.	Decrease	Increase	Rev.[S]	10.0 Sec.
Rev.[n]	Reversal Attempts	1-25 attempts	Decrease	Increase	Rev.[n]	5 attempts
Range	Current Range	1, 3, 5, 8 Amp.	8 --> 1	1 --> 8	"Cur"	5 Amp.
Relay 1	Relay 1 Polarity	N. Inv./Invert.	N.Inv<-->Inv	N.Inv<-->Inv	"Pol"	N. Inverted
Relay 2	Relay 2 Polarity	N. Inv./Invert.	N.Inv<-->Inv	N.Inv<-->Inv	"Pol"	N. Inverted

The HPL440 is programmed by the use of only three keys located on the front panel. The mode key is used to switch the display from showing kW [%] to display one of seven programmable parameters. All the parameters and their programming ranges are listed in the function table above. The red mode LED is used to show which parameter may be altered. When a parameter has been selected by the mode key the value may be altered by the two arrow-keys. Parameters are stored in EEPROM. Note that the function of the keys is repeated if held down continuously. When no key has been activated for about 5 seconds the display returns to the kW [%] position (normal operation). When the Dip. Sw. 1 is 'On' the unit is protected against programming; but it is still possible to display current settings.

LED Usage	
Blocking Fwd.	Fwd. LED flashing
Blocking Rev.	Rev. LED flashing
Start Delay	TsLED lit
Relay 1 Closed	Relay 1 LED lit
Relay 2 Closed	Relay 2 LED lit

Phase Error	Display
Phase order L1 L3 L2	PH 1 (flashing)

DIP Switch Usage		
SW 1	Unit protected	ON
SW 2	Phase order sup.	ON
SW 3	Not used	Off
SW 4	Pause 2 Sec.	Off
SW 4	Pause 0.5 Sec.	ON

The Phase order supervision generates an alarm if the three phases L1, L2 and L3 have been reversed. A phase error activates the relays in exactly the same way as non-recoverable blocking (both relays deactivated) and the display shows which type of error has occurred. A phase error is automatically reset when it has been corrected. During a phase error the 4-20mA signal lout is set to 0 mA (possible remote alarm signaling).

## Dip. Switch Access.

1. Disconnect the Mains Power.
2. Remove the plastic cover. (Use a small screwdriver).
3. Change the switch settings and assemble the unit again.

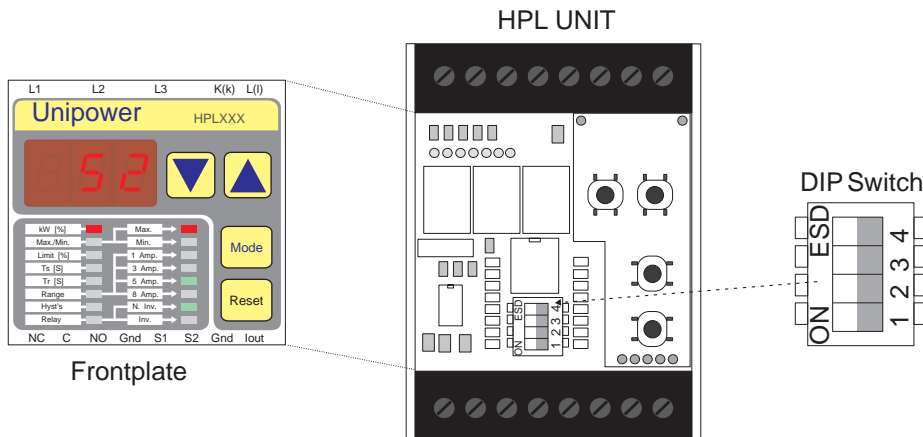

## Function.

The drawing below shows a typical AC-motor power consumption curve recorded from a conveyor machine that is being blocked by foreign goods etc. The machine is controlled by an HPL440, which is programmed for 1 reversal (Rev.[n] = 1) in order to attempt just a single automatic fault recovery cycle. The programmable start timer (Ts) is used to filter out from the protection/regulation cycle the large peak power consumption generated by the motor when starting. The Ts delay function

moves forward. After Ts has expired the machine is blocked by some material, a piece of wood etc. and the Fwd. relay is deactivated and the machine is stopped. After a pause-delay the machine changes direction and the transport is reversed for a programmable time duration. The pause-delay of either 2 or 0.5 seconds is meant to protect the motor and machinery during reversals. After the reversal has completed, a new pause is introduced after which the machinery proceeds in the forward direction again. If the blocking was successfully removed the machinery proceeds in the

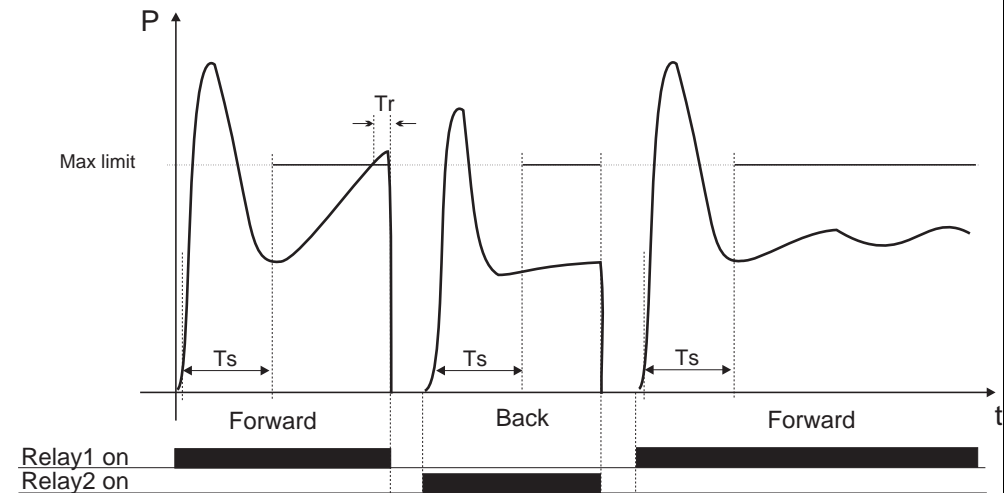

is activated after the power consumption reaches 5%. When Ts expires, the max. kW limit becomes active. If the power consumption drops below 5%, the supervision is switched off again. The drawing also shows how the reaction timer (Tr) becomes active after the limit has been exceeded. Tr is fixed to 100ms in the HPL440, but is changeable upon customer request. Together with two motor-switches the HPL440 implements the functions necessary to control an automatic reversal function of the machinery. The following text refers to the drawing shown on this page. When the HPL440 is connected to the mains supply the Fwd. relay is activated and the conveyor machine

forward direction as shown in the figure until it is either stopped or a new blocking occurs. Otherwise if the machine is still blocked after 1 reversal the machine is stopped with a non-recoverable blocking error. The HPL440 has been designed in a way so that the conveyour transport is stopped in the reversed position. In case of a non-recoverable blocking the signal lout is set to 0 mA. The Rev.[n] counter is reset after some time dependant of Rev.[S] and Ts. The HPL440 supervises both directions, but a blocking in the reverse direction makes the machine stop immediately.